

S Helical-Worm Gearmotor

Modified date 04/2021

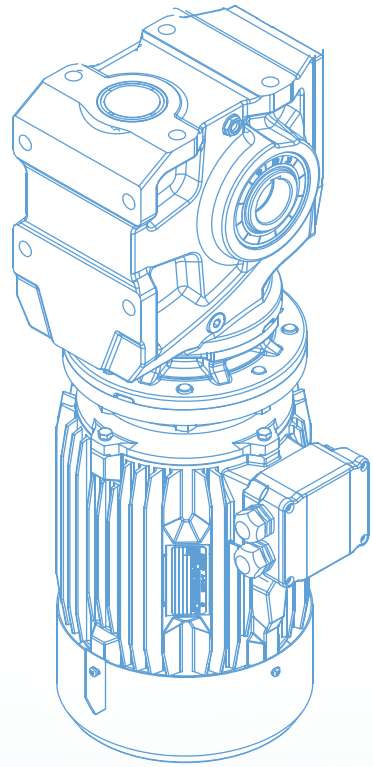
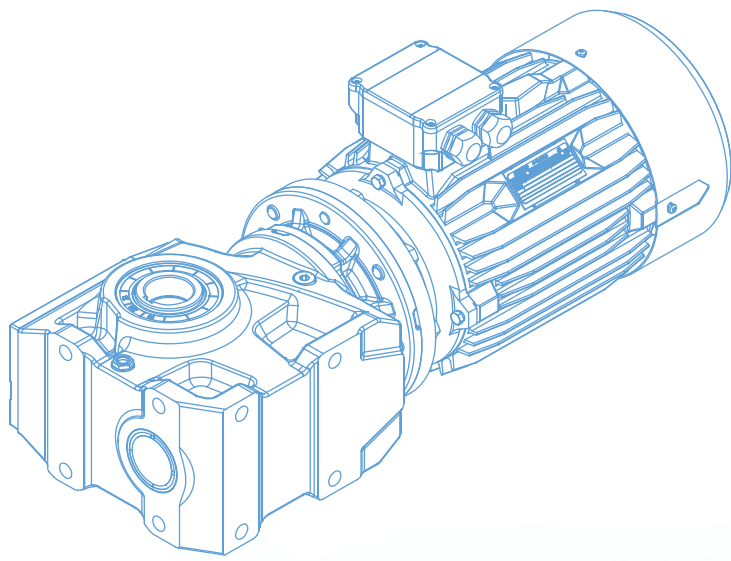

S Series Helical-worm gear units

Power range: 0.12–45kW

Ratio: 23.8–389 (imax: 26688)

Torque: 73–10200 N.m

Features

- » Low backlash gearmotor designed with flexible and modular concept.
- » Small size and large center distance transmission structure, with 10% higher torque transmission capacity and load shock resistance.
- » The FEA design of the casting housing, which improves the running stability by 30% and effectively reduces the noise of the whole machine.
- » The large-modulus gear design and enhanced bearing arrangement ensure higher reliability and longer service life.
- » Up to 95% modular design, international production, faster production and logistics cycles.
- » Higher power density can save you mounting space and the overall structure is more compact.
- » High reliability and long design life can effectively reduce your use and maintenance costs.

Part characteristics

- » Housing materials are high strength grey cast iron and nodular cast iron.
- » Gears, pinions and bevel gears are made of high grade alloy with carburize-harden technology. Hardness of teeth surface reaches 58-62 HRC, grinding precision reaching class5-6 and even 3 if required.
- » Shafts are made of alloy via heat treatment.
- » Standard accessories such as bearings and oil seals are provided by international and national famous brands.
- » Good assembly environment, standardized assembly technology, 100% strict quality assurance inspection and regular type test.
- » The material of worm wheel is tin bronze, the worm rod is alloy steel, which is grinded after carburizing and quenching.

Main application

- » Modular, high standardization, components of few specifications and models.
- » Wide power, torque, speed ratio covering range.
- » The products are widely applied in electricity, coal, cement, metallurgy, harbor, agriculture, shipping, lifting, environment protection, stage, logistic, weaving, paper making, light industry, plastics and other regions.
- » Cement & material
- » Paper industry
- » Chemical & recycling





Contents

1	Type Designation	2
2	Sectional Drawings	4
3	Mounting Positions	5
4	Type Selection and Example	6
5	Transmission Capacity	8
6	Permissible Radial Force	12
7	Dimensions	14
8	Input Flange and Input shaft	32
9	Combi-type Dimensions	37
10	Motor Rainproof Cover Dimensions	38
11	Recommended Dimensions for Driven Equipment Shaft	39
12	Shaft End Centre Hole	41
13	Dimension od Parallel Key and Keyway	42
12	Oil	43



1 Type Designation

K 3 08 H A - C32 - D1 0 0 -

Series _____

Stages _____

2-stage

Size _____

Mounting Mode _____

H=Horizontal foot-mounted
 F=Flange-mounted
 S=Short flange-mounted
 A=Torque arm-mounted
 T=Torque arm-mounted with accessory

Output Mode _____

A/B/D/E=Unidirectional output shaft
 C/F=Bidirectional output shaft
 G/H=Hollow shaft with parallel key
 I/J=Hollow shaft with shrink disk
 K/L=Hollow shaft with involute spline

Nominal Ratio Code _____

Mounting Positions _____

D1/D2/D3/D4/D5/D6

Accessories and Specific Configuration _____

0=None
 6=Oil compensating tank

Oil Code _____

0=Without oil filling(Please select this option when you do not need lubricating oil);
 4=With mineral oil VG680(Please select this option when the ambient temperature is -20°C~+40°C, and you need lubricating oil);
 B=With synthetic lubricating oil VG460(It is recommended to select this option when you need lubricating oil and the ambient temperature is below 0°C);

Note ¹⁾ Motor Type/Frame Size/Poles/Power Code

Power kW	4-pole Type	6-pole Type	Power kW	4-pole Type	6-pole Type	Power kW	4-pole Type	6-pole Type	Power kW	4-pole Type	6-pole Type
0.09	MS056M4A09		1.1	MS090S4B11 MH090S4B11 MP090S4B11 MA090S4B11	MH090S6B11 MP090M6B11	11	MH160S4C11 MP160M4C11 MA160M4C11	MH160M6C11 MP160M6C11	110	MH315S4D11 MP315S4D11	MH315L6D11
0.12	MH063M4A12 MP063M4A12 MA063M4A12		1.5	MS090S4B15 MH090S4B15 MP090M4B15 MA090M4B15	MH100M6B15 MP100M6B15	15	MH160M4C15 MP160L4C15 MA160L4C15	MH180M6C15 MP180M6C15	132	MH315M4D13 MP315M4D13	MH315L6D13
0.18	MH063M4A18 MP063M4A18 MA063M4A18	MH071M6A18 MP071M6A18	2.2	MS100M4B22 MH100M4B22 MP100M4B22 MA100M4B22	MH112M6B22 MP112M6B22	18.5	MH180M4C18 MP180M4C18 MA180M4C18	MH200M6C18 MP200M6C18	160	MH315L4D16 MP315L4D16	
0.25	MH071M4A25 MP071M4A25 MA071M4A25	MH071M6A25 MP071M6A25	3	MS100M4B30 MH100M4B30 MP100M4B30 MA100M4B30	MH132S6B30 MP132S6B30	22	MH180L4C22 MP180L4C22 MA180L4C22	MH200M6C22 MP200M6C22	200	MH315L4D20 MP315L4D20	
0.37	MH071M4A37 MP071M4A37 MA071M4A37	MH080M6A37 MP080M6A37	4	MS112M4B40 MH112L4B40 MP112L4B40 MA112L4B40	MH132M6B40 MP132S6B40	30	MH200M4C30 MP200M4C30 MA200M4C30	MH225M6C30 MP225M6C30			
0.55	MS080M4A55 MH080M4A55 MP080M4A55 MA080M4A55	MH080M6A55 MP080M6A55	5.5	MS132S4B55 MH132S4B55 MP132M4B55 MA132M4B55	MH132M6B55 MP132M6B55	37	MH225M4C37 MP225M4C37 MA225M4C37	MH250M6C37 MP250M6C37			
0.75	MS080M4A75 MH080M4A75 MP080M4A75 MA080M4A75	MH090S6A75 MP090S6A75	7.5	MS132M4B75 MH132M4B75 MP132L4B75 MA132L4B75	MH160S6B75 MP160S6B75	45	MH225M4C45 MP225M4C45 MA225M4C45	MH280S6C45 MP280S6C45			
						55	MH250M4C55 MP250M4C55 MA250M4C55	MH280M6C55 MP280M6C55			
						75	MH280S4C75 MP280S4C75 MA280S4C75	MH315S6C75 MP315S6C75			
						90	MH280M4C90 MP280M4C90 MA280M4C90	MH315M6C90 MP315M6C90			

MH 132S 4 B55 A C 3 - A 0 B 1 0 - 0 1 1

Cable Entry Position
1/2/3/4

Terminal Box Position
1/2/3/4

Motor mounting Position 0

Motor protection

0=IP55 Without rainproof cover 2=IP56 Without rainproof cover 4=IP65 Without rainproof cover
1=IP55 With rainproof cover 3=IP56 With rainproof cover 5=IP65 With rainproof cover

Thermal Protection and Heating Protection

0=Without thermal protection and heating Protection 2=Thermal switch 5=Thermistor and heating belt
1=Thermistor 3= PT100 temperature sensor 6=Thermal switch and heating belt
4=Heating belt 7= PT100 temperature sensor and heating belt

Brake

N=Without brake
A=Brake 220-240VAC G=Brake with self-lock device 220-240VAC P=Double-brakes 220-240VAC
B=Brake 380-415VAC H=Brake with self-lock device 380-415VAC Q=Double-brakes 380-415VAC
C=Brake 440-480VAC J=Brake with self-lock device 440-480VAC X=Double-brakes 440-480VAC
D=Brake with release handle 220-240VAC K=Brake with micro switch 220-240VAC R=Double-brakes with release handle 220-240VAC
E=Brake with release handle 380-415VAC L=Brake with micro switch 380-415VAC S=Double-brakes with release handle 380-415VAC
F=Brake with release handle 440-480VAC M=Brake with micro switch 440-480VAC T=Double-brakes with release handle 440-480VAC

Encoder

0=Without encoder 2=With standard encoder accessories 4=With encoder E25C
1=With encoder 3=With encoder E25B

Cooling

A=Self-fan cooling
F=Driven fan

Frequency/Voltage Code

1=50Hz 220VΔ/380VY 5=60Hz 440VΔ D=60Hz 480VΔ
2=50Hz 230VΔ/400VY 6=60Hz 460VΔ G=60Hz 230VY
3=50Hz 380VΔ/660VY 7=60Hz 440VY H=60Hz 230VΔ
4=50Hz 400VΔ/690VY 8=60Hz 460VY J=60Hz 575VY
A=50Hz 240VΔ/415VY C=60Hz 480VY K=60Hz 575VΔ

Note: 3kW and below "Y", alternative code: 1,2,7,8,A,C,E; MA motor exclusive code: 6,8,G,H,J,K.
4kW and above "Δ", alternative code: 3,4,5,6,B,D,F.

Frame Material

L=Die-casting aluminum frame(standard configuration of 100 and below)
C=Grey cast iron frame(standard configuration of 112 and above)

Mounting Mode A

Power Code ¹⁾

Motor Poles ¹⁾

4=4-pole; 6=6-pole

Frame Size ¹⁾

Motor Type ¹⁾

MS=Three-phase asynchronous motor (IE1)
MH=High efficiency three-phase asynchronous motor (IE2)
MP=Premium Efficiency three-phase asynchronous motor (IE3)
MA=NEMA efficiency three-phase asynchronous motor
YZ=Crane and metallurgical applications three-phase asynchronous motor
YG=Variable-frequency three-phase induction motor for roll table application

- Example of product type with input flange or input shaft:
- Example of product type with input flange and motor type:
- Combi-type designation:

S208HA-C32-D100-AE3
S208HA-C32-D100-AP132-MH132S4B55FC3-A0N10-011
S208HA/C205-D28-D100-MH080M4A75AL1-A0N00-011





2 Sectional Drawings

S

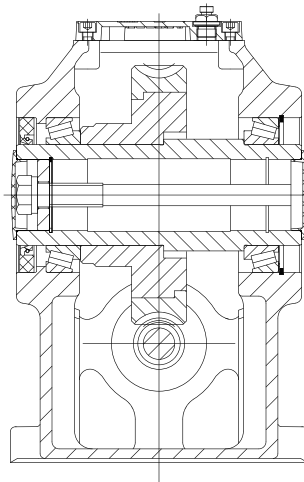
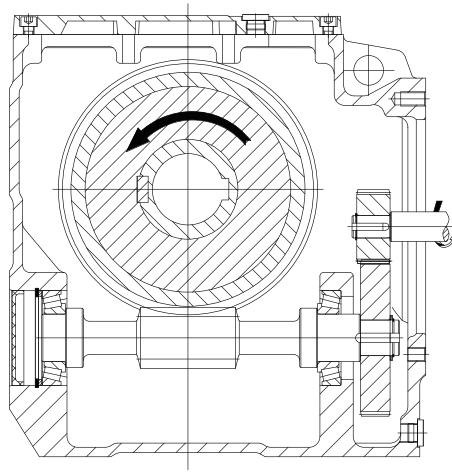

3 Mounting Positions

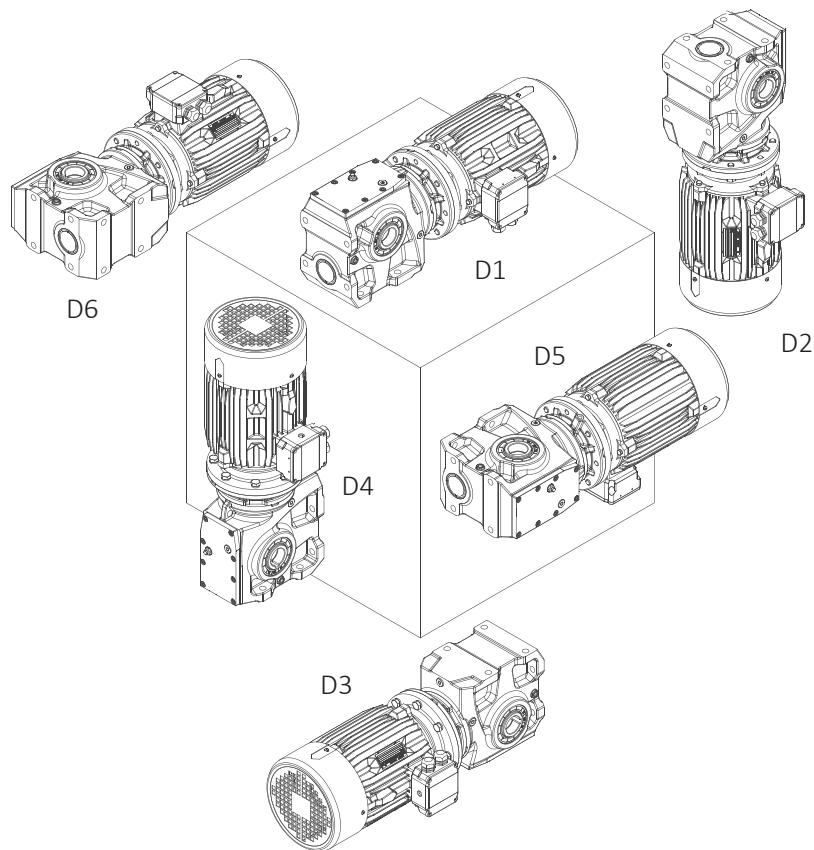

S

Motor terminal box and cable entry position (View: Motor afterbody)

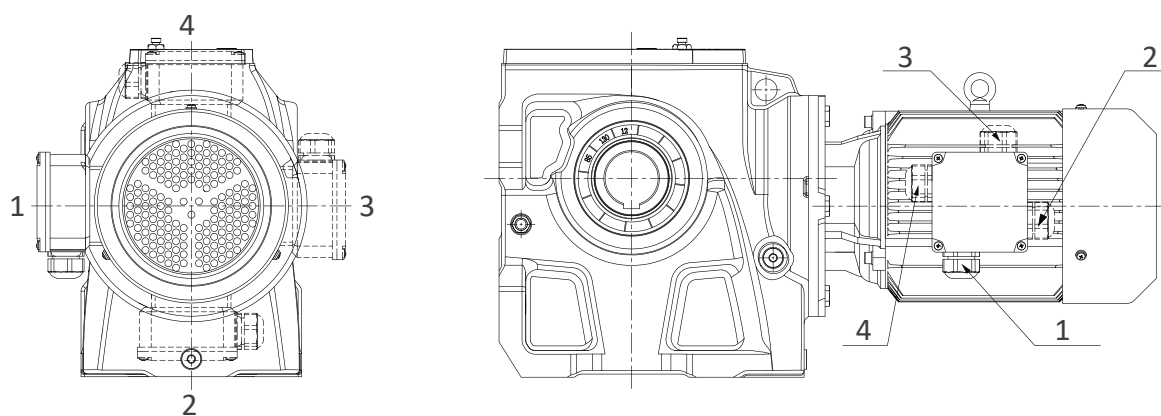

Please consult us about the selection of cable entry positions.

Assembly colour of gearmotor

S203-S212

 (RAL5015)



4 Type Selection and Example

Steps	Description	Symbols	Parameters calculation and guidelines							
1	Driven machine factor	f_1	Load Characteristic	Operating hours per day (h)						
				≤ 2	2~10	10~24				
			Uniform	1.00(1.00)	1.00(1.25)	1.25(1.50)				
			Moderate	1.00(1.25)	1.25(1.50)	1.50(1.75)				
			Heavy	1.25(1.50)	1.50(1.75)	1.75(2.00)				
Note: Apply values in the brackets when starts per hour are 10 times or more. If the equipment continues working and the operating times ≤ 10 h per day, then $f_1 > 1.25$.										
2	Ambient temperature factor	f_t	Load Characteristic	Ambient temperature						
				20	25	30	35	40	45	50
			Uniform	1.00	1.00	1.00	1.03	1.06	1.12	1.20
			Moderate	1.00	1.01	1.02	1.06	1.12	1.16	1.30
			Heavy	1.00	1.02	1.04	1.10	1.17	1.20	1.40
Note: The usual working condition is: ambient temperature $-10 \sim +40^\circ\text{C}$, uniform or moderate shock, utilization ratio $\leq 90\%$, working hours/d ≤ 8 , and input speed ≤ 1800 rpm. If not within this range, add fans to the worm shaft end of gear units type S205 and above.										
3	input Speed	n_1	≤ 1800 r/min Consult us if higher speed required.							
4	Calculation of the Ratio	i	$i = n_1/n_2$							
5	Transmission efficiency	η	$i=7.1-16$	$i=18-50$	$i=56-112$	$i=125-500$	S/C Combi-type			
			η	88%	77%	62%	57%	57%		
6	Calculation of the input power of the gear unit on basis of the torque and power required by the driven machine.	P_1	$P_1 = T_2 \cdot n_1 / (9550 \cdot i \cdot \eta)$ or $P_1 = P_2 / \eta$							
7	Determination of gear unit type referring to the table of transmission capacity after calculation, For directly-connected motor, require to refer to directly-connected motor power table.	T_{2N} , P_{1N}	$T_{2N} \geq T_2 \cdot f_1 \cdot f_t$ or $P_{1N} \geq P_1 \cdot f_1 \cdot f_t$							
8	Check the radial and axial forces on the shafts	F_{r1}/F_{r2} F_{a1}/F_{a2}	See P9							
9	Determination of lubrication system		Generally splash lubrication							
10	Determination of cooling system		Generally air cooling or fan cooling							
11	Determination of every item included in the type designation		For details about type designation, see P1.							
12	Normal ambient conditions		Ambient temperature -10 to 40°C , ample space, good ventilation, altitude not exceeding 1000m and common plant dust.							
13	Special ambient conditions		For higher or lower temperature, dusty sites, chemical reaction (acids, alkaline, etc), or open field (sunlight, ice, rain, etc), please consult us!							

Example

◆ Known Criteria:

1. Load characteristics by the driven machine:

Moderate, working 8 hours/d, ambient temperature 40°C, and starting 10 times/h;

2. Normal motor: 4-pole,

speed $n_1=1450\text{r/min}$;

3. The power required $P_2=1\text{kW}$,

speed $n_2=10.4\text{r/min}$;

4. Mounting mode: flange-mounted, unidirectional output shaft A,

mounting position D1, motor terminal box 2, cable entry position 1.

◆ Selection steps:

1. By referring to the table of Load Characteristic,

we get the driven machine factor $f_1=1.5$,

the ambient temperature factor $f_2=1.12$;

2. Calculation of the Ratio i_N :

$i=N_1/N_2=1450/10.4=139.4$, nominal ratio $i_N=140$;

3. Calculation of the input power and determination of the motor power

(transmission efficiency $\eta=57\%$):

$P_1 \geq P_2/\eta=1/0.57=1.8\text{kW}$, so 2.2kW motor is selected.

Refer to the directly-connected motor power table, it can be directly-connected;

4. Determination of the nominal power of the geared motor P_{1N} :

$P_{1N} \geq P_2 \cdot f_1/\eta=1 \times 1.5 \times 1.12/0.57=2.9\text{kW}$;

5. The type selected:

S208FA-D14-D100-MS100M4B322AL2-A0N00-021



5.1 S Series Transmission capacity

S...(iN=7.1-500)

				S203			S204			S205			S206		
n ₁ (r/min)	n _{2N} (r/min)	Code	i _N	T _{2N} (N·m)	i _{ex}	P _{1N} (kW)	T _{2N} (N·m)	i _{ex}	P _{1N} (kW)	T _{2N} (N·m)	i _{ex}	P _{1N} (kW)	T _{2N} (N·m)	i _{ex}	P _{1N} (kW)
1450	204	B71	7.1	55	6.81	1.39	110	7.28	2.61				330	7.03	8.1
	181	B80	8	55	7.68	1.24	110	8.03	2.36	200	7.93	4.35	350	8.37	7.2
	161	B90	9	55	8.75	1.08	110	9.05	2.10	200	8.90	3.88	380	9.32	7.0
	145	C10	10	60	9.89	1.05	110	10.3	1.84	200	10.1	3.43	380	10.3	6.4
	129	C11	11.2	60	11.2	0.92	110	11.7	1.63	220	11.2	3.40	380	11.6	5.6
	116	C13	12.5	60	12.1	0.86	110	13.2	1.44	220	12.8	2.97	400	12.7	5.4
	104	C14	14	65	14.1	0.79	120	14.2	1.46	220	14.1	2.70	430	14.5	5.1
	90.6	C16	16	70	16.0	0.75	120	15.8	1.31	220	15.8	2.40	450	15.4	5.0
	80.6	C18	18	65	17.6	0.73	120	17.4	1.36	220	18.8	2.31	450	17.9	4.95
	72.5	C20	20	70	19.3	0.72	135	19.7	1.35	220	21.1	2.06	450	20.5	4.32
	64.7	C22	22.4	75	21.0	0.70	150	22.4	1.32	230	23.8	1.91	450	23.3	3.80
	58.0	C25	25	75	24.0	0.62	160	25.3	1.25	250	26.4	1.87	450	26.1	3.40
	51.8	C28	28	80	27.1	0.58	160	28.7	1.10	250	30.3	1.63	450	29.1	3.05
	46.0	C32	31.5	80	30.7	0.51	160	30.9	1.02	250	33.2	1.48	480	31.9	2.96
	40.8	C36	35.5	80	33.0	0.48	160	35.3	0.89	260	37.5	1.37	480	36.3	2.61
	36.3	C40	40	80	38.7	0.41	160	38.9	0.81	260	40.1	1.28	480	39.7	2.39
	32.2	C45	45	85	43.8	0.38	165	43.9	0.74	260	44.5	1.15	510	45.1	2.23
	29.0	C50	50	85	48.3	0.35	180	50.0	0.71	290	50.3	1.14	540	48.0	2.22
	25.9	C56	56	80	55.9	0.35	155	56.5	0.67	245	55.8	1.08	480	53.8	2.19
	23.0	C63	63	85	63.1	0.33	160	64.0	0.61	270	63.9	1.03	500	61.6	1.99
	20.4	C71	71	85	71.9	0.29	160	68.9	0.57	300	70.3	1.05	500	70.0	1.75
	18.1	C80	80	85	81.3	0.26	170	78.2	0.53	300	79.2	0.93	500	78.3	1.56
	16.1	C90	90	90	92.0	0.24	170	89.1	0.47	300	87.6	0.84	520	87.2	1.46
	14.5	D10	100	95	99.1	0.23	170	100.7	0.41	310	98.9	0.77	520	95.8	1.33
	12.9	D11	112	90	116.0	0.19	170	114.0	0.37	300	109.8	0.67	520	117.6	1.08
	11.6	D13	125	100	131.4	0.20	170	122.8	0.37	300	125.8	0.64	520	129.3	1.07
	10.4	D14	140	100	144.9	0.18	170	143.7	0.32	300	138.3	0.58	520	146.8	0.94
	9.06	D16	160	100	158.4	0.17	170	162.9	0.28	300	155.9	0.51	520	160.5	0.86
	8.06	D18	180	100	173.2	0.15	170	179.6	0.25	300	166.6	0.48	520	182.6	0.76
	7.25	D20	200					170	196.3	0.23	300	193.6	0.41	520	194.1
6.47	D22	224					170	214.6	0.21	300	217.9	0.37	520	224.4	0.62
5.80	D25	250											520	266.8	0.52
5.18	D28	280											520	283.9	0.49
4.60	D32	315											520	320.7	0.43
4.08	D36	355													
3.63	D40	400													
3.22	D45	450													
2.90	D50	500													

Note: (1) Actual output speed of the gearmotor: Actual input speed (n₁)/Exact ratio (i_{ex});

(2) Rated input power corresponding to actual input speed of the gearmotor: P_{1N}=T_{2N}*n₁/ (9550*i_{ex}), the rated output torque T_{2N} in the formula remains unchanged.

S207			S208			S209			S210			S212						
T _{2N} (N·m)	i _{ex}	P _{1N} (kW)	T _{2N} (N·m)	i _{ex}	P _{1N} (kW)	T _{2N} (N·m)	i _{ex}	P _{1N} (kW)	T _{2N} (N·m)	i _{ex}	P _{1N} (kW)	T _{2N} (N·m)	i _{ex}	P _{1N} (kW)	i N	Code	n _{2N} (r/min)	n ₁ (r/min)
															7.1	B71	204	
700	7.41	16.3													8	B80	181	
750	8.44	15.3													9	B90	161	
750	9.35	13.8	1300	9.80	22.9										10	C10	145	
750	10.7	12.1	1300	11.1	20.1										11.2	C11	129	
750	12.1	10.7	1300	12.9	17.4										12.5	C13	116	
820	13.6	10.4	1300	14.1	15.9										14	C14	104	
880	15.5	9.8	1450	15.8	15.8										16	C16	90.6	
850	17.2	9.7	1380	17.4	15.7	2700	18.4	28.9	3800	17.9	41.8	7000	18.1	76	18	C18	80.6	
950	19.7	9.5	1550	20.1	15.2	2700	21.0	25.4	3800	19.6	38.2	7000	20.2	68	20	C20	72.5	
1000	22.2	8.9	1600	21.4	14.8	2700	24.3	21.9	4000	23.2	34.0	7000	23.8	58	22.4	C22	64.7	
1050	23.9	8.7	1600	24.3	13.0	2900	26.5	21.6	4100	26.0	31.1	7400	25.9	56	25	C25	58.0	
1050	27.2	7.6	1600	29.8	10.6	3100	29.8	20.5	4300	27.7	30.6	7700	30.2	50	28	C28	51.8	
1100	30.1	7.2	1600	32.6	9.7	3300	32.6	19.9	4600	31.7	28.6	8200	33.5	48.3	31.5	C32	46.0	
1100	34.5	6.3	1600	37.7	8.4	3300	37.7	17.3	4700	35.3	26.3	8600	35.5	47.8	35.5	C36	40.8	
1100	38.8	5.6	1600	40.2	7.8	3300	40.2	16.2	4700	40.0	23.2	8600	40.3	42.0	40	C40	36.3	
1100	43.4	5.00	1600	45.7	6.9	3300	47.1	13.8	4700	44.8	20.7	8700	45.1	38.0	45	C45	32.2	
1100	48.3	4.49	1700	48.9	6.8	3600	50.5	14.1	4900	51.2	18.9	9000	50.1	35.4	50	C50	29.0	
1000	57.6	4.25	1400	57.8	5.9	3300	54.7	14.8	4400	55.0	19.6	8000	55.4	35.4	56	C56	25.9	
1100	64.8	4.16	1500	65.0	5.7	3300	59.6	13.6	4700	60.2	19.1	8600	62.0	34.0	63	C63	23.0	1450
1100	70.9	3.80	1700	71.2	5.8	3300	72.9	11.1	4600	71.2	15.8	8600	73.1	28.8	71	C71	20.4	
1100	83.3	3.23	1800	82.3	5.4	3300	82.9	9.8	4600	79.8	14.1	8600	79.3	26.5	80	C80	18.1	
1100	91.9	2.93	1900	87.7	5.3	3300	88.7	9.1	4700	85.2	13.5	8500	92.6	22.5	90	C90	16.1	
1200	105.5	2.79	2000	102.9	4.76	3300	104.7	7.7	4900	97.4	12.3	9250	102.7	22.1	100	D10	14.5	
1200	118.6	2.48	2000	115.7	4.23	3600	117.8	7.5	5000	112.3	10.9	9000	108.9	20.2	112	D11	12.9	
1200	132.6	2.41	2000	126.9	4.20	3700	129.1	7.6	5200	128.4	10.8	9200	121.5	20.2	125	D13	11.6	
1300	147.6	2.35	2100	146.6	3.82	3800	149.1	6.8	5300	142.8	9.9	9500	134.6	18.8	140	D14	10.4	
1300	161.8	2.14	2200	156.3	3.75	3900	159.0	6.5	5400	161.9	8.9	9600	162.3	15.8	160	D16	9.06	
1300	175.9	1.97	2300	180.5	3.39	4000	183.7	5.8	5600	181.5	8.2	9900	181.5	14.5	180	D18	8.06	
1300	197.7	1.75	2300	205.2	2.99	4000	208.8	5.1	5600	207.1	7.2	10200	201.6	13.5	200	D20	7.25	
1300	216.6	1.60	2300	228.0	2.69	4000	232.0	4.59	5700	220.8	6.9	10200	236.0	11.5	224	D22	6.47	
1300	254.3	1.36	2300	256.5	2.39	4000	261.0	4.08	5700	253.8	6.0	10200	253.7	10.7	250	D25	5.80	
1300	282.6	1.23	2300	282.2	2.17	4000	287.1	3.71	5700	285.4	5.3	10200	285.2	9.5	280	D28	5.18	
1300	310.9	1.11	2300	308.3	1.99	4000	313.7	3.40	5700	315.2	4.82	10200	328.2	8.3	315	D32	4.60	
1300	350.6	0.99	2300	357.0	1.72	4000	363.3	2.93	5700	354.4	4.28	10200	365.1	7.4	355	D36	4.08	
			2300	393.8	1.56	4000	400.7	2.66	5700	419.2	3.62	10200	429.4	6.3	400	D40	3.63	
			2300	465.0	1.32	4000	473.2	2.25				10200	466.1	5.8	450	D45	3.22	
			2300	519.7	1.18	4000	528.8	2.01							500	D50	2.90	

S



5.2 S.../C... Combi-type transmission capacity

S.../C... (iN=200-18000)

n ₁ (r/min)	n _{2N} (r/min)	Code	i _{N=i₁Nx_i2N}	T _{2N}	i _{ex}	P _{1N}	T _{2N}	i _{ex}	P _{1N}	T _{2N}	i _{ex}	P _{1N}	T _{2N}	i _{ex}	P _{1N}	T _{2N}	i _{ex}	P _{1N}			
				(N·m)		(kW)	(N·m)		(kW)	(N·m)		(kW)	(N·m)		(kW)	(N·m)		(kW)	(N·m)		(kW)
				S203/C201			S204/C201			S205/C203			S206/C203			S207/C203					
S203/C301			S204/C301			S205/C303			S206/C303			S207/C303									
1450	7.25	D20	200=12.5x16	100	199.7	0.13	180	217.8	0.22	310	195.8	0.42	540	194.3	0.74	1300	185.1	1.87			
	6.47	D22	224=12.5x18	100	227.5	0.12	180	248.2	0.19	310	221.4	0.37	540	219.7	0.65	1300	209.3	1.65			
	5.80	D25	250=35.5x7.1	100	225.7	0.12	180	241.5	0.20	310	266.3	0.31	540	257.7	0.56	1300	245.0	1.41			
	5.18	D28	280=35.5x8	100	269.0	0.10	180	287.7	0.17	310	300.8	0.27	540	291.1	0.49	1300	276.7	1.25			
	4.60	D32	315=35.5x9	100	298.3		180	319.1	0.15	310	333.8	0.25	540	323.1	0.45	1300	307.1	1.13			
	4.08	D36	355=35.5x10	100	333.3		180	356.5	0.13	310	382.5	0.22	540	370.3	0.39	1300	351.9	0.98			
	3.63	D40	400=35.5x11.2	100	353.1		180	377.7	0.13	310	420.0	0.20	540	406.6	0.35	1300	386.4	0.90			
	3.22	D45	450=35.5x12.5	100	422.4		180	451.8	0.11	310	472.5	0.17	540	457.4	0.31	1300	434.7	0.80			
	2.90	D50	500=35.5x14	100	475.2		180	508.3		310	506.3	0.16	540	490.1	0.29	1300	465.8	0.74			
	2.59	D56	560=35.5x16	100	544.5		180	582.5		310	573.8	0.14	540	555.4	0.26	1300	527.9	0.66			
	2.30	D63	630=35.5x18	100	620.4		180	663.6		310	648.8	0.13	540	628.0	0.23	1300	596.9	0.58			
	2.04	D71	710=35.5x20	100	673.2		180	720.1		310	738.8	0.11	540	715.1	0.20	1300	679.7	0.51			
	1.81	D80	800=35.5x22.4	100	732.6		180	783.7		310	832.5		540	805.9	0.18	1300	765.9	0.45			
	1.61	D90	900=35.5x25	100	811.8		180	868.4		310	945.0		540	914.8	0.16	1300	869.4	0.40			
	1.45	E10	1000=35.5x28	100	907.5		180	970.8		310	1009		540	976.5	0.15	1300	928.1	0.37			
	1.29	E11	1120=35.5x31.5	100	1066		180	1140		310	1136		540	1100	0.13	1300	1045	0.33			
	1.16	E13	1250=35.5x35.5	100	1148		180	1228		310	1294		540	1252	0.11	1300	1190	0.29			
	1.04	E14	1400=35.5x40	100	1274		180	1363		310	1466		540	1419		1300	1349	0.26			
	0.91	E16	1600=35.5x45	100	1422		180	1521		310	1658		540	1604		1300	1525	0.23			
	0.81	E18	1800=35.5x50	100	1670		180	1786		310	1785		540	1728		1300	1642	0.21			
	0.73	E20	2000=35.5x56	100	1795		180	1920		310	2089		540	2022		1300	1922	0.18			
	0.65	E22	2240=35.5x63							310	2370		540	2294		1300	2180	0.16			
		0.58	E25	2500=63x40	100	2436		180	2470		310	2498		540	2409		1300	2534	0.14		
		0.52	E28	2800=63x45	100	2720		180	2758		310	2824		540	2723		1300	2864	0.12		
		0.46	E32	3150=63x50	100	3193		180	3238		310	3042		540	2932		1300	3084	0.11		
		0.41	E36	3550=63x56	100	3433		180	3482		310	3559		540	3431		1300	3609			
		0.36	E40	4000=63x63							310	4038		540	3893		1300	4095			
	0.32	E45	4500=63x71							310	4447		540	4287		1300	4510				
	0.29	E50	5000=63x80							310	4863		540	4688		1300	4931				
	0.26	E56	5600=63x90							310	5316		540	5125		1300	5391				
	0.23	E63	6300=160x40							310	6096		540	6276		1300	6326				
	0.20	E71	7100=160x45							310	6891		540	7094		1300	7152				
	0.18	E80	8000=160x50							310	7421		540	7640		1300	7702				
	0.16	E90	9000=160x56							310	8684		540	8940		1300	9012				
	0.15	F10	10000=160x63							310	9853		540	10144		1300	10226				
	0.13	F11	11200=160x71							310	10851		540	11171		1300	11261				
	0.12	F13	12500=160x80							310	11864		540	12214		1300	12313				
	0.10	F14	14000=160x90							310	12971		540	13354		1300	13462				
	0.09	F16	16000=160x100																		
	0.08	F18	18000=160x112																		



6 Permissible Radial Force

6.1 Radial force on input shaft (Fr1)(N)

S

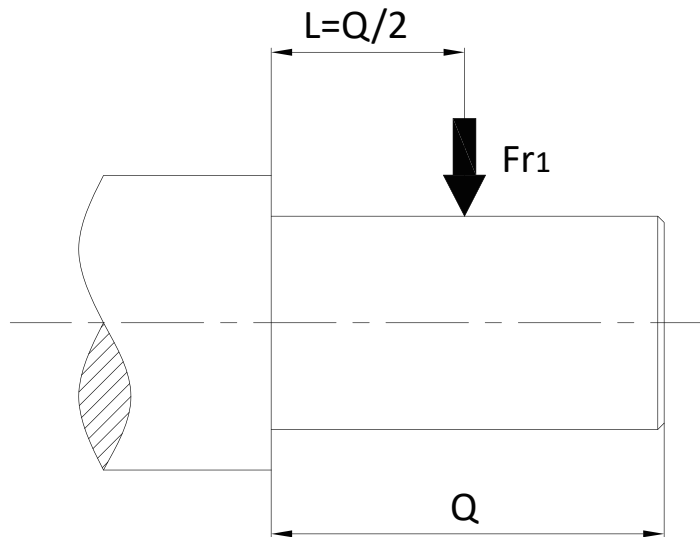

	Fr1(N)								
	S203	S204	S205	S206	S207	S208	S209	S210	S212
AE2	803	803	803	803	803	803	/	/	/
AE3	/	/	1504	1504	1504	1504	1504	1504	/
AE4	/	/	/	/	2188	2188	2188	2188	2188
AE5	/	/	/	/	/	/	4207	4207	4207
AE6	/	/	/	/	/	/	/	5664	5664
AE7	/	/	/	/	/	/	/	/	9957

6.1 Radial force on output shaft (Fr_2)(N)

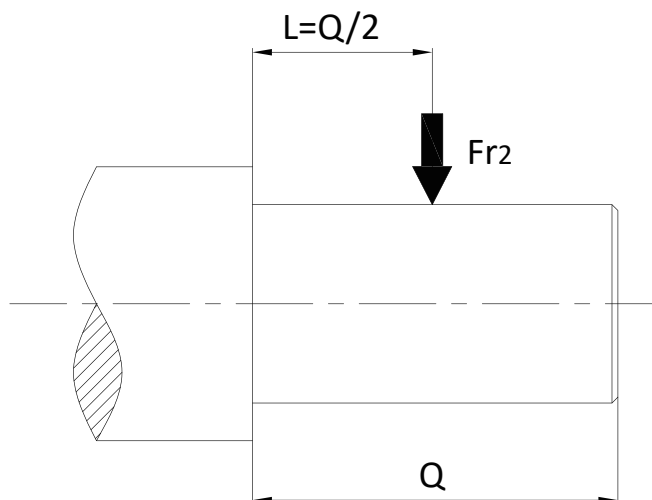

n_{2N} (r/min)	Fr_2 (N)								
	S203	S204	S205	S206	S207	S208	S209	S210	S212
200–224	370	520	860	860	870	3170	3620	5190	7270
180–200	460	650	1080	1070	1090	3960	4530	6490	9090
160–180	580	810	1350	1340	1360	4950	5660	8110	11360
125–160	720	1010	1680	1670	1700	6190	7070	10140	14200
112–125	900	1270	2110	2090	2120	7740	8840	12680	17760
100–112	1120	1580	2630	2610	2650	9680	11050	15850	22200
90–100	1400	1980	3290	3270	3310	12100	13820	19810	27740
80–90	1760	2480	4110	4090	4140	15120	17270	24760	34680
56–80	2151	3035	5041	5007	5075	18530	21165	30345	42500
45–56	2380	3332	5542	5304	6265	20995	24650	35275	47600
40–45	2380	3502	5814	5559	6571	22100	25840	36975	49725
35.5–40	2550	3502	5950	6163	6919	23035	26605	38063	51255
31.5–35.5	2550	3766	6222	6163	7438	23970	27880	39950	53720
28–31.5	2550	4004	6392	6851	7659	24650	28985	41565	56100
26.528	2550	4123	6392	6851	8203	24650	29325	43095	60350
22.4–26.5	2550	4522	6392	7370	9860	24650	29325	43095	60350
≤22.4	2550	4556	6392	7378	10455	24650	29325	43095	60350

Corresponding motor dimension table for S203

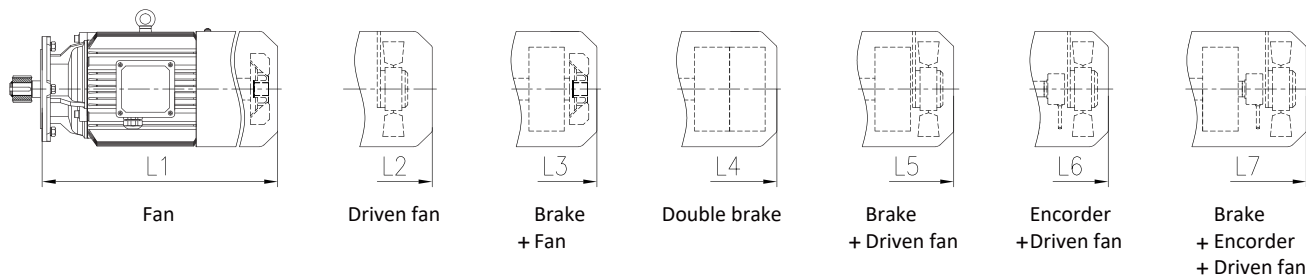

Directly connected motor dimension table

4-pole power (kW)	Range of Ratio	MS							MH							MP							MA							D
		L1	L2	L3	L4	L5	L6	L7	L1	L2	L3	L5	L6	L7	L1	L2	L3	L5	L6	L7	L1	L2	L3	L5	L6	L7				
0.12	7.1-180	/	261	241	/	296	/	/	206	261	241	296	/	/	206	261	241	296	/	/	206	261	241	296	/	/	124			
0.18	7.1-180	/	261	241	/	296	/	/	206	261	241	296	/	/	206	261	241	296	/	/	206	261	241	296	/	/	124			
0.25	7.1-100	/	268	263	/	313	313	353	223	268	263	313	313	353	223	268	263	313	313	353	223	273	263	318	318	358	139			
0.37	7.1-63	/	268	263	/	313	313	353	223	268	263	313	313	353	223	268	263	313	313	353	223	273	263	318	318	358	139			
0.55	7.1-35.5	299	344	359	419	404	404	454	299	344	359	404	404	454	299	344	359	404	404	454	299	344	359	404	404	449	162			
0.75	7.1-25	299	344	359	419	404	404	454	299	344	359	404	404	454	299	344	359	404	404	454	299	344	359	404	404	449	162			

Directly connected motor weight table / kg

4-pole power (kW)	Range of Ratio	MS							MH							MP							MA						
		M1	M2	M3	M4	M5	M6	M7	M1	M2	M3	M5	M6	M7	M1	M2	M3	M5	M6	M7	M1	M2	M3	M5	M6	M7			
0.12	7.1-180	/	8	9	/	9	/	/	7	8	9	9	/	/	7	8	9	9	/	/	7	7.5	8.5	9	/	/			
0.18	7.1-180	/	8	9	/	9	/	/	7	8	9	9	/	/	8	9	10	10	/	/	8	8.5	9.5	10	/	/			
0.25	7.1-100	/	9	10	/	11	10	12	8	9	10	11	10	12	9	10	11	12	11	13	9	10	10.5	11.5	10.5	12.5			
0.37	7.1-63	/	10	11	/	12	11	13	9	10	11	12	11	13	10	11	12	13	12	14	10	11	11.5	12.5	11.5	13.5			
0.55	7.1-35.5	13	14	17	21	18	15	19	14	15	18	19	16	20	15	16	19	20	17	21	15	16	19	20	16.5	21			
0.75	7.1-25	14	15	18	22	19	16	20	15	16	19	20	17	21	16	17	20	21	18	22	16	17	20	21	17.5	22			



S

S204 Dimensions

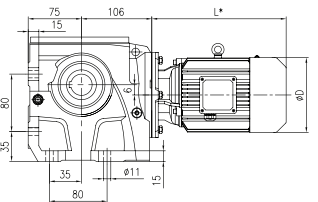
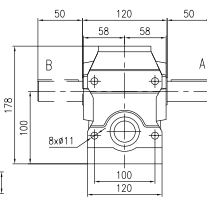
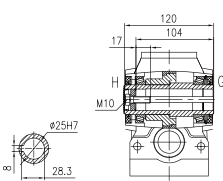
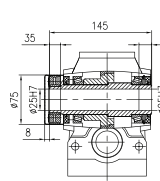
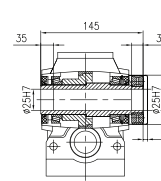
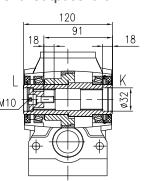
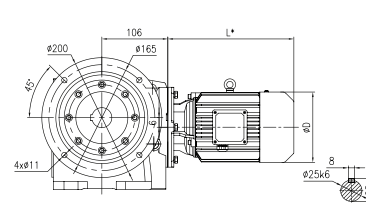
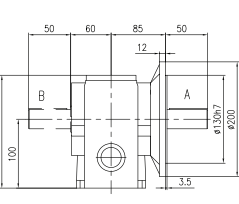
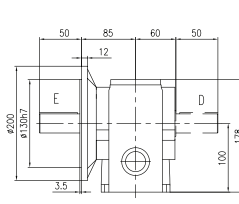
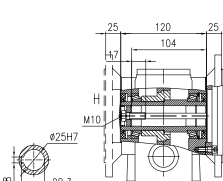
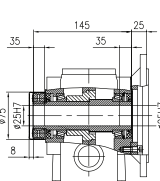
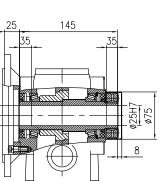
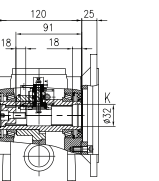
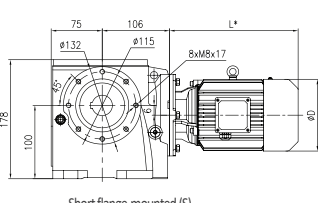
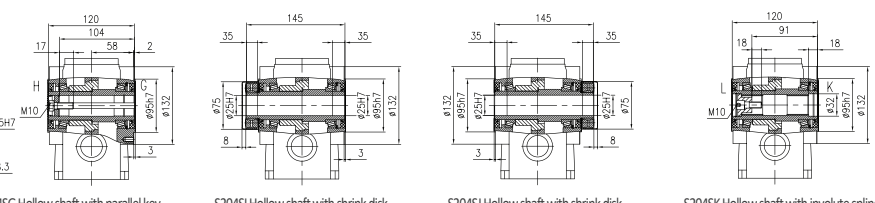
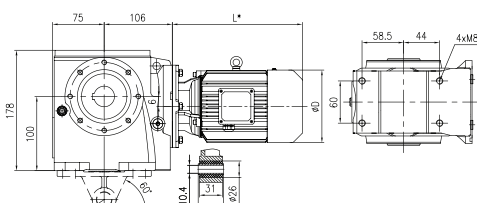
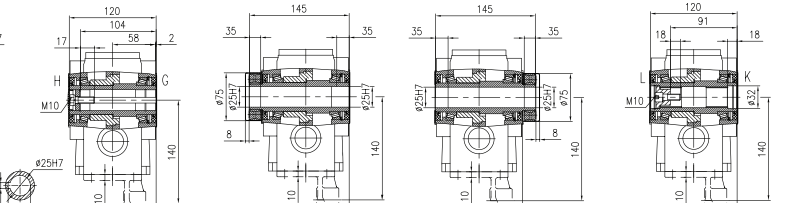
Mounting Mode	S204 Dimensions				
Horizontal foot-mounted	 <p>Horizontal foot-mounted (H) Weight: 10kg (Without motor and oil)</p>		 <p>S204HA Unidirectional output shaft S204HB Unidirectional output shaft S204HC Bidirectional output shaft</p>		
	 <p>S204HG Hollow shaft with parallel key S204HH Hollow shaft with parallel key</p>	 <p>S204HI Hollow shaft with shrink disk</p>	 <p>S204HJ Hollow shaft with shrink disk</p>	 <p>S204HK Hollow shaft with involute spline S204HL Hollow shaft with involute spline</p>	
Flange-mounted	 <p>Flange-mounted (F) Weight: 13kg (Without motor and oil)</p>		 <p>S204FA Unidirectional output shaft S204FB Unidirectional output shaft S204FC Bidirectional output shaft</p>		 <p>S204FD Unidirectional output shaft S204FE Unidirectional output shaft S204FF Bidirectional output shaft</p>
	 <p>S204FG Hollow shaft with parallel key S204FH Hollow shaft with parallel key</p>	 <p>S204FI Hollow shaft with shrink disk</p>	 <p>S204FJ Hollow shaft with shrink disk</p>	 <p>S204FK Hollow shaft with involute spline S204FL Hollow shaft with involute spline</p>	
Short flange-mounted	 <p>Short flange-mounted (S) Weight: 10kg (Without motor and oil)</p>		 <p>S204SG Hollow shaft with parallel key S204SH Hollow shaft with parallel key S204SJ Hollow shaft with shrink disk S204SK Hollow shaft with involute spline S204SL Hollow shaft with involute spline</p>		
Torque arm-mounted	 <p>Torque arm-mounted with accessory (T) Weight: 11.5kg (Without motor and oil)</p> <p>Torque arm-mounted without accessory (A) Weight: 10kg (Without motor and oil)</p>		 <p>S204AG Hollow shaft with parallel key S204AH Hollow shaft with parallel key S204AT Hollow shaft with parallel key S204TH Hollow shaft with parallel key S204AI Hollow shaft with shrink disk S204TI Hollow shaft with shrink disk S204AJ Hollow shaft with involute spline S204AL Hollow shaft with involute spline S204AT Hollow shaft with involute spline S204TL Hollow shaft with involute spline</p>		

Note: Involute spline size DIN 5480: m1.25×Z18×α30×D25×9H

Corresponding motor dimension table for S204

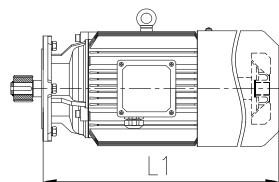

Fan

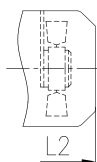

Driven fan

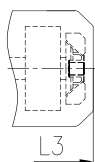

Brake + Fan

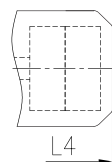

Double brake

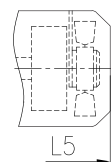

Brake + Driven fan

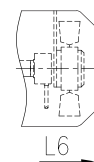

Encoder + Driven fan

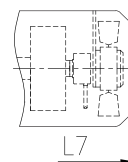

Brake + Encoder + Driven fan

Directly connected motor dimension table

4-pole power (kW)	Range of Ratio	MS							MH							MP							MA							D
		L1	L2	L3	L4	L5	L6	L7	L1	L2	L3	L5	L6	L7	L1	L2	L3	L5	L6	L7	L1	L2	L3	L5	L6	L7				
0.12	7.1-224	/	261	241	/	296	/	/	206	261	241	296	/	/	206	261	241	296	/	/	206	261	241	296	/	/	124			
0.18	7.1-224	/	261	241	/	296	/	/	206	261	241	296	/	/	206	261	241	296	/	/	206	261	241	296	/	/	124			
0.25	7.1-224	/	268	263	/	313	313	353	223	268	263	313	313	353	223	268	263	313	313	353	223	273	263	318	318	358	139			
0.37	7.1-140	/	268	263	/	313	313	353	223	268	263	313	313	353	223	268	263	313	313	353	223	273	263	318	318	358	139			
0.55	7.1-90	299	344	359	419	404	404	454	299	344	359	404	404	454	299	344	359	404	404	454	299	344	359	404	404	449	162			
0.75	7.1-63	299	344	359	419	404	404	454	299	344	359	404	404	454	299	344	359	404	404	454	299	344	359	404	404	449	162			
1.1	7.1-35.5	322	367	377	437	422	422	477	322	367	377	422	422	477	322	367	377	422	422	477	347	392	402	452	452	497	176			
1.5	7.1-20	322	367	377	437	422	422	477	322	367	377	422	422	477	347	392	402	447	447	502	347	392	402	452	452	497	176			

Directly connected motor weight table / kg

4-pole power (kW)	Range of Ratio	MS							MH							MP							MA							
		M1	M2	M3	M4	M5	M6	M7	M1	M2	M3	M5	M6	M7	M1	M2	M3	M5	M6	M7	M1	M2	M3	M5	M6	M7				
0.12	7.1-224	/	8	9	/	9	/	/	7	8	9	9	/	/	7	8	9	9	/	/	7	7.5	8.5	9	/	/				
0.18	7.1-224	/	8	9	/	9	/	/	7	8	9	9	/	/	8	9	10	10	/	/	8	8.5	9.5	10	/	/				
0.25	7.1-224	/	9	10	/	11	10	12	8	9	10	11	10	12	9	10	11	12	11	13	9	10	10.5	11.5	10.5	12.5				
0.37	7.1-140	/	10	11	/	12	11	13	9	10	11	12	11	13	10	11	12	13	12	14	10	11	11.5	12.5	11.5	13.5				
0.55	7.1-90	13	14	17	21	18	15	19	14	15	18	19	16	20	15	16	19	20	17	21	15	16	19	20	16.5	21				
0.75	7.1-63	14	15	18	22	19	16	20	15	16	19	20	17	21	16	17	20	21	18	22	16	17	20	21	17.5	22				
1.1	7.1-35.5	16	17	20	24	21	18	22	18	19	22	23	20	24	21	22	25	26	23	27	23	24	27	28	24.5	29				
1.5	7.1-20	17	18	21	25	22	19	23	19	20	23	24	21	25	23	24	27	28	25	29	23	24	27	28	24.5	29				

Corresponding motor dimension table for S205

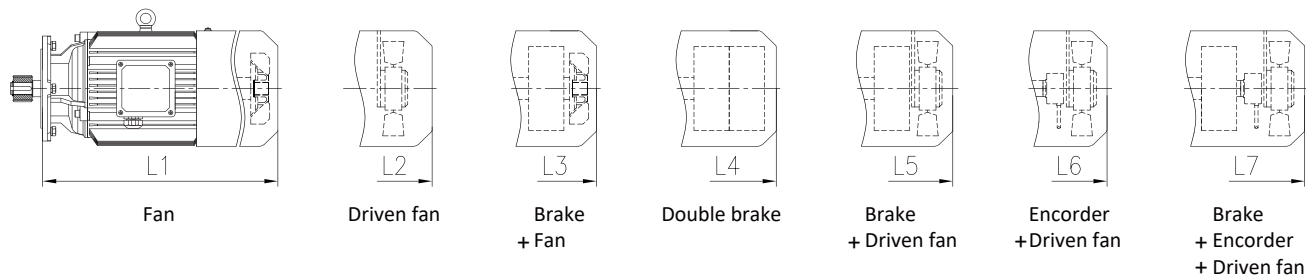

Directly connected motor dimension table

4-pole power (kW)	Range of Ratio	MS							MH							MP							MA							D
		L1	L2	L3	L4	L5	L6	L7	L1	L2	L3	L5	L6	L7	L1	L2	L3	L5	L6	L7	L1	L2	L3	L5	L6	L7				
0.12	8-224	/	262	242	/	297	/	/	207	262	242	297	/	/	207	262	242	297	/	/	207	262	242	297	/	/	124			
0.18	8-224	/	262	242	/	297	/	/	207	262	242	297	/	/	207	262	242	297	/	/	207	262	242	297	/	/	124			
0.25	8-224	/	269	264	/	314	314	354	224	269	264	314	314	354	224	269	264	314	314	354	224	274	264	319	319	359	139			
0.37	8-224	/	269	264	/	314	314	354	224	269	264	314	314	354	224	269	264	314	314	354	224	274	264	319	319	359	139			
0.55	8-180	300	345	360	420	405	405	455	300	345	360	405	405	455	300	345	360	405	405	455	300	345	360	405	405	450	162			
0.75	8-125	300	345	360	420	405	405	455	300	345	360	405	405	455	300	345	360	405	405	455	300	345	360	405	405	450	162			
1.1	8-80	323	368	378	438	423	423	478	323	368	378	423	423	478	323	368	378	423	423	478	348	393	403	453	453	498	176			
1.5	8-40	323	368	378	438	423	423	478	323	368	378	423	423	478	348	393	403	448	448	503	348	393	403	453	453	498	176			
2.2	8-25	395	435	470	530	510	510	565	395	435	470	510	510	565	395	435	470	510	510	565	395	450	470	530	530	575	202			

Directly connected motor weight table / kg

4-pole power (kW)	Range of Ratio	MS							MH							MP							MA							
		M1	M2	M3	M4	M5	M6	M7	M1	M2	M3	M5	M6	M7	M1	M2	M3	M5	M6	M7	M1	M2	M3	M5	M6	M7				
0.12	8-224	/	8	9	/	9	/	/	7	8	9	9	/	/	7	8	9	9	/	/	7	7.5	8.5	9	/	/				
0.18	8-224	/	8	9	/	9	/	/	7	8	9	9	/	/	8	9	10	10	/	/	8	8.5	9.5	10	/	/				
0.25	8-224	/	9	10	/	11	10	12	8	9	10	11	10	12	9	10	11	12	11	13	9	10	10.5	11.5	10.5	12.5				
0.37	8-224	/	10	11	/	12	11	13	9	10	11	12	11	13	10	11	12	13	12	14	10	11	11.5	12.5	11.5	13.5				
0.55	8-180	13	14	17	21	18	15	19	14	15	18	19	16	20	15	16	19	20	17	21	15	16	19	20	16.5	21				
0.75	8-125	14	15	18	22	19	16	20	15	16	19	20	17	21	16	17	20	21	18	22	16	17	20	21	17.5	22				
1.1	8-80	16	17	20	24	21	18	22	18	19	22	23	20	24	21	22	25	26	23	27	23	24	27	28	24.5	29				
1.5	8-40	17	18	21	25	22	19	23	19	20	23	24	21	25	23	24	27	28	25	29	23	24	27	28	24.5	29				
2.2	8-25	27	28	35	42	36	29	37	30	31	38	39	32	40	32	33	40	41	34	42	36	37	44	45	38	45				



S206 Dimensions

Mounting Mode					
Horizontal foot-mounted	<p style="text-align: center;">Horizontal foot-mounted (H) Weight: 25kf (Without motor and oil)</p> <p style="text-align: center;">S206HA Unidirectional output shaft S206HB Unidirectional output shaft S206HC Bidirectional output shaft</p>				
	<p style="text-align: center;">S206HG Hollow shaft with parallel key S206HH Hollow shaft with parallel key</p> <p style="text-align: center;">S206HI Hollow shaft with shrink disk</p> <p style="text-align: center;">S206HJ Hollow shaft with shrink disk</p> <p style="text-align: center;">S206HK Hollow shaft with involute spline S206HL Hollow shaft with involute spline</p>				
Flange-mounted	<p style="text-align: center;">Flange-mounted (F) Weight: 30kg (Without motor and oil)</p> <p style="text-align: center;">S206FA Unidirectional output shaft S206FB Unidirectional output shaft S206FC Bidirectional output shaft</p> <p style="text-align: center;">S206FD Unidirectional output shaft S206FE Unidirectional output shaft S206FF Bidirectional output shaft</p>				
	<p style="text-align: center;">S206FG Hollow shaft with parallel key S206FH Hollow shaft with parallel key</p> <p style="text-align: center;">S206FI Hollow shaft with shrink disk</p> <p style="text-align: center;">S206FJ Hollow shaft with shrink disk</p> <p style="text-align: center;">S206FK Hollow shaft with involute spline S206FL Hollow shaft with involute spline</p>				
Short flange-mounted	<p style="text-align: center;">Short flange-mounted (S) Weight: 25kg (Without motor and oil)</p> <p style="text-align: center;">S206SG Hollow shaft with parallel key S206SH Hollow shaft with parallel key</p> <p style="text-align: center;">S206SI Hollow shaft with shrink disk</p> <p style="text-align: center;">S206SJ Hollow shaft with shrink disk</p> <p style="text-align: center;">S206SK Hollow shaft with involute spline S206SL Hollow shaft with involute spline</p>				
Torque arm-mounted	<p style="text-align: center;">Torque arm-mounted with accessory (T) Weight: 28kg (Without motor and oil)</p> <p style="text-align: center;">Torque arm-mounted without accessory (A) Weight: 25kg (Without motor and oil)</p> <p style="text-align: center;">S206AG Hollow shaft with parallel key S206AH Hollow shaft with parallel key S206TG Hollow shaft with parallel key S206TH Hollow shaft with parallel key</p> <p style="text-align: center;">S206AJ Hollow shaft with shrink disk S206TJ Hollow shaft with shrink disk</p> <p style="text-align: center;">S206AK Hollow shaft with involute spline S206AL Hollow shaft with involute spline S206TK Hollow shaft with involute spline S206TL Hollow shaft with involute spline</p>				

Note: Involute spline size DIN 5480: m2×Z16×α30×D35×9H

Corresponding motor dimension table for S206

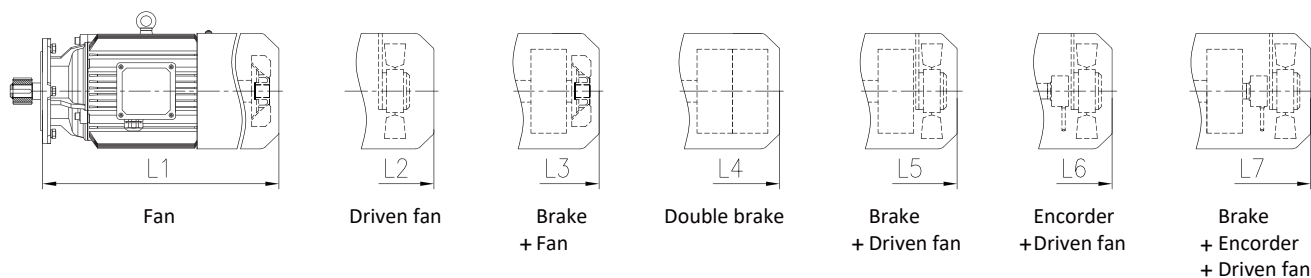

Directly connected motor dimension table

4-pole power (kW)	Range of Ratio	MS							MH							MP							MA							D
		L1	L2	L3	L4	L5	L6	L7	L1	L2	L3	L5	L6	L7	L1	L2	L3	L5	L6	L7	L1	L2	L3	L5	L6	L7				
0.18	180-315	/	262	242	/	297	/	/	207	262	242	297	/	/	207	262	242	297	/	/	207	262	242	297	/	/	124			
0.25	125-315	/	269	264	/	314	314	354	224	269	264	314	314	354	224	269	264	314	314	354	224	274	264	319	319	359	139			
0.37	80-315	/	269	264	/	314	314	354	224	269	264	314	314	354	224	269	264	314	314	354	224	274	264	319	319	359	139			
0.55	50-280	300	345	360	420	405	405	455	300	345	360	405	405	455	300	345	360	405	405	455	300	345	360	405	405	450	162			
0.75	28-224	300	345	360	420	405	405	455	300	345	360	405	405	455	300	345	360	405	405	455	300	345	360	405	405	450	162			
1.1	18-140	323	368	378	438	423	423	478	323	368	378	423	423	478	323	368	378	423	423	478	348	393	403	453	453	498	176			
1.5	10-100	323	368	378	438	423	423	478	323	368	378	423	423	478	348	393	403	448	448	503	348	393	403	453	453	498	176			
2.2	7.1-71	395	435	470	530	510	510	565	395	435	470	510	510	565	395	435	470	510	510	565	395	450	470	530	530	575	202			
3	7.1-40	395	435	470	530	510	510	565	395	435	470	510	510	565	395	435	470	510	510	565	395	450	470	530	530	575	202			
4	7.1-25	391	441	466	526	516	516	571	459	509	534	584	584	639	459	509	534	584	584	639	459	519	534	599	599	639	220			

Directly connected motor weight table / kg

4-pole power (kW)	Range of Ratio	MS							MH							MP							MA						
		M1	M2	M3	M4	M5	M6	M7	M1	M2	M3	M5	M6	M7	M1	M2	M3	M5	M6	M7	M1	M2	M3	M5	M6	M7			
0.18	180-315	/	8	9	/	9	/	/	7	8	9	9	/	/	8	9	10	10	/	/	8	8.5	9.5	10	/	/			
0.25	125-315	/	9	10	/	11	10	12	8	9	10	11	10	12	9	10	11	12	11	13	9	10	10.5	11.5	10.5	12.5			
0.37	80-315	/	10	11	/	12	11	13	9	10	11	12	11	13	10	11	12	13	12	14	10	11	11.5	12.5	11.5	13.5			
0.55	50-280	13	14	17	21	18	15	19	14	15	18	19	16	20	15	16	19	20	17	21	15	16	19	20	16.5	21			
0.75	28-224	14	15	18	22	19	16	20	15	16	19	20	17	21	16	17	20	21	18	22	16	17	20	21	17.5	22			
1.1	18-140	16	17	20	24	21	18	22	18	19	22	23	20	24	21	22	25	26	23	27	23	24	27	28	24.5	29			
1.5	10-100	17	18	21	25	22	19	23	19	20	23	24	21	25	23	24	27	28	25	29	23	24	27	28	24.5	29			
2.2	7.1-71	27	28	35	42	36	29	37	30	31	38	39	32	40	32	33	40	41	34	42	36	37	44	45	38	45			
3	7.1-40	30	31	38	45	39	32	40	33	34	41	42	35	43	36	37	44	45	38	46	36	37	44	45	38	45			
4	7.1-25	45	46	53	61	54	47	55	52	53	60	61	54	62	56	57	64	65	58	66	56	57	64	65	58	66			



S

S207 Dimensions

Mounting Mode	S207 Dimensions											
Horizontal foot-mounted	<p>Horizontal foot-mounted (H) Weight: 45kg (Without motor and oil)</p>				<p>S207HA Unidirectional output shaft S207HB Unidirectional output shaft S207HC Bidirectional output shaft</p>							
	<p>S207HG Hollow shaft with parallel key S207HH Hollow shaft with parallel key</p>		<p>S207HI Hollow shaft with shrink disk S207HJ Hollow shaft with shrink disk</p>		<p>S207HI Hollow shaft with shrink disk S207HJ Hollow shaft with shrink disk</p>		<p>S207HK Hollow shaft with involute spline S207HL Hollow shaft with involute spline</p>					
Flange-mounted	<p>Flange-mounted (F) Weight: 52.5kg (Without motor and oil)</p>				<p>S207FA Unidirectional output shaft S207FB Unidirectional output shaft S207FC Bidirectional output shaft</p> <p>S207FD Unidirectional output shaft S207FE Unidirectional output shaft S207FF Bidirectional output shaft</p>							
	<p>S207FG Hollow shaft with parallel key S207FH Hollow shaft with parallel key</p>		<p>S207FI Hollow shaft with shrink disk S207FJ Hollow shaft with shrink disk</p>		<p>S207FI Hollow shaft with shrink disk S207FJ Hollow shaft with shrink disk</p>		<p>S207FK Hollow shaft with involute spline S207FL Hollow shaft with involute spline</p>					
Short flange-mounted	<p>Short flange-mounted (S) Weight: 45kg (Without motor and oil)</p>				<p>S207SG Hollow shaft with parallel key S207SH Hollow shaft with parallel key</p>		<p>S207SI Hollow shaft with shrink disk S207SJ Hollow shaft with shrink disk</p>		<p>S207SK Hollow shaft with involute spline S207SL Hollow shaft with involute spline</p>			
Torque arm-mounted	<p>Torque arm-mounted with accessory (T) Weight: 50kg (Without motor and oil)</p> <p>Torque arm-mounted without accessory (A) Weight: 45kg (Without motor and oil)</p>				<p>S207AG Hollow shaft with parallel key S207AH Hollow shaft with parallel key S207TG Hollow shaft with parallel key S207TH Hollow shaft with parallel key</p>		<p>S207AI Hollow shaft with shrink disk S207TI Hollow shaft with shrink disk</p>		<p>S207AJ Hollow shaft with shrink disk S207TJ Hollow shaft with shrink disk</p>		<p>S207AK Hollow shaft with involute spline S207AL Hollow shaft with involute spline S207TK Hollow shaft with involute spline S207TL Hollow shaft with involute spline</p>	

Note: Involute spline size DIN 5480: m2xZ24xα30xD50x9H

Corresponding motor dimension table for S207

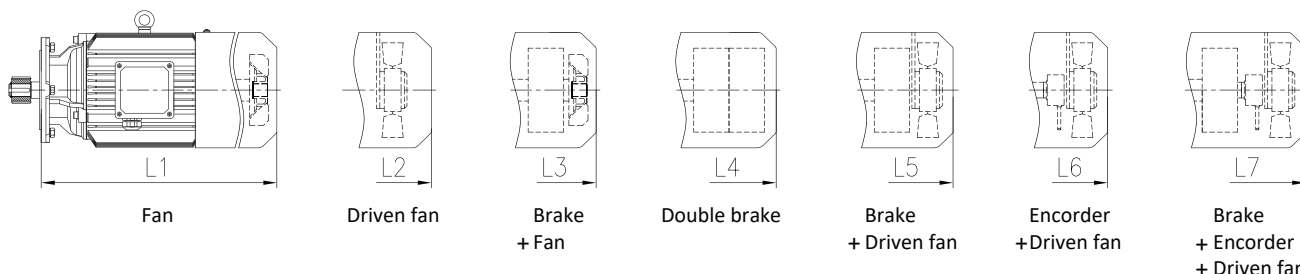

Directly connected motor dimension table

4-pole power (kW)	Range of Ratio	MS							MH							MP							MA							D
		L1	L2	L3	L4	L5	L6	L7	L1	L2	L3	L4	L5	L6	L7	L1	L2	L3	L5	L6	L7	L1	L2	L3	L5	L6	L7			
0.37	224-355	/	261	256	/	306	306	346	216	261	256	/	306	306	346	216	261	256	306	306	346	216	266	256	311	311	351	139		
0.55	140-355	292	337	352	412	397	397	447	292	337	352	/	397	397	447	292	337	352	397	397	447	292	337	352	397	397	442	162		
0.75	80-355	292	337	352	412	397	397	447	292	337	352	/	397	397	447	292	337	352	397	397	447	292	337	352	397	397	442	162		
1.1	50-250	315	360	370	430	415	415	470	315	360	370	/	415	415	470	315	360	370	415	415	470	340	385	395	445	445	490	176		
1.5	35.5-250	315	360	370	430	415	415	470	315	360	370	/	415	415	470	340	385	395	440	440	495	340	385	395	445	445	490	176		
2.2	22.4-200	387	427	462	522	502	502	557	387	427	462	/	502	502	557	387	427	462	502	502	557	387	442	462	522	522	567	202		
3	11.2-125	387	427	462	522	502	502	557	387	427	462	/	502	502	557	387	427	462	502	502	557	387	442	462	522	522	567	202		
4	8-80	383	433	458	518	508	508	563	451	501	526	/	576	576	631	451	501	526	576	576	631	451	511	526	591	591	631	220		
5.5	8-40	421	471	501	566	546	546	601	421	471	501	/	546	546	601	459	509	539	584	584	639	497	562	577	647	647	677	259		
7.5	8-35.5	459	509	539	604	584	584	639	459	509	539	/	584	584	639	497	547	577	622	622	677	497	562	577	647	647	677	259		

Directly connected motor weight table / kg

4-pole power (kW)	Range of Ratio	MS							MH							MP							MA						
		M1	M2	M3	M4	M5	M6	M7	M1	M2	M3	M4	M5	M6	M7	M1	M2	M3	M5	M6	M7	M1	M2	M3	M5	M6	M7		
0.37	224-355	/	10	11	/	12	11	13	9	10	11	/	12	11	13	10	11	12	13	12	14	10	11	11.5	12.5	11.5	13.5		
0.55	140-355	13	14	17	21	18	15	19	14	15	18	/	19	16	20	15	16	19	20	17	21	15	16	19	20	16.5	21		
0.75	80-355	14	15	18	22	19	16	20	15	16	19	/	20	17	21	16	17	20	21	18	22	16	17	20	21	17.5	22		
1.1	50-250	16	17	20	24	21	18	22	18	19	22	/	23	20	24	21	22	25	26	23	27	23	24	27	28	24.5	29		
1.5	35.5-250	17	18	21	25	22	19	23	19	20	23	/	24	21	25	23	24	27	28	25	29	23	24	27	28	24.5	29		
2.2	22.4-200	27	28	35	42	36	29	37	30	31	38	/	39	32	40	32	33	40	41	34	42	36	37	44	45	38	45		
3	11.2-125	30	31	38	45	39	32	40	33	34	41	/	42	35	43	36	37	44	45	38	46	36	37	44	45	38	45		
4	8-80	45	46	53	61	54	47	55	52	53	60	/	61	54	62	56	57	64	65	58	66	56	57	64	65	58	66		
5.5	8-40	63	65	74	85	76	66	77	67	69	78	/	80	70	81	77	79	88	90	80	91	88	90	99	101	91	102		
7.5	8-35.5	73	75	84	95	86	76	87	80	82	91	/	93	83	94	88	90	99	101	91	102	88	90	99	101	91	102		



S208 Dimensions

Mounting Mode					
<div style="background-color: #cccccc; padding: 5px; font-weight: bold; font-size: 24px; width: 30px; margin: 0 auto;">S</div> Horizontal foot-mounted	<p>Horizontal foot-mounted (H) Weight: 85kg (Without motor and oil)</p> <p>S208HA Unidirectional output shaft S208HB Unidirectional output shaft S208HC Bidirectional output shaft</p> <p>S208HG Hollow shaft with parallel key S208HH Hollow shaft with parallel key</p> <p>S208HI Hollow shaft with shrink disk</p> <p>S208HI Hollow shaft with shrink disk</p> <p>S208HI Hollow shaft with shrink disk</p> <p>S208HK Hollow shaft with involute spline S208HL Hollow shaft with involute spline</p>				
Flange-mounted	<p>Flange-mounted (F) Weight: 98kg (Without motor and oil)</p> <p>S208FA Unidirectional output shaft S208FB Unidirectional output shaft S208FC Bidirectional output shaft</p> <p>S208FD Unidirectional output shaft S208FE Unidirectional output shaft S208FF Bidirectional output shaft</p> <p>S208FG Hollow shaft with parallel key S208FH Hollow shaft with parallel key</p> <p>S208FI Hollow shaft with shrink disk</p> <p>S208FJ Hollow shaft with shrink disk</p> <p>S208FK Hollow shaft with involute spline S208FL Hollow shaft with involute spline</p>				
Short flange-mounted	<p>Short flange-mounted (S) Weight: 85kg (Without motor and oil)</p> <p>S208SG Hollow shaft with parallel key S208SH Hollow shaft with parallel key</p> <p>S208SI Hollow shaft with shrink disk</p> <p>S208SI Hollow shaft with shrink disk</p> <p>S208SJ Hollow shaft with shrink disk</p> <p>S208SK Hollow shaft with involute spline S208SL Hollow shaft with involute spline</p>				
Torque arm-mounted	<p>Torque arm-mounted with accessory (T) Weight: 95kg (Without motor and oil)</p> <p>Torque arm-mounted without accessory (A) Weight: 85kg (Without motor and oil)</p> <p>S208AG Hollow shaft with parallel key S208AH Hollow shaft with parallel key S208TG Hollow shaft with parallel key S208TH Hollow shaft with parallel key</p> <p>S208AI Hollow shaft with shrink disk S208TI Hollow shaft with shrink disk</p> <p>S208AJ Hollow shaft with shrink disk S208TJ Hollow shaft with shrink disk</p> <p>S208AK Hollow shaft with involute spline S208AL Hollow shaft with involute spline S208TK Hollow shaft with involute spline S208TL Hollow shaft with involute spline</p>				

Note: Involute spline size DIN 5480: m2xZ31xα30xD65x9H

Corresponding motor dimension table for S208

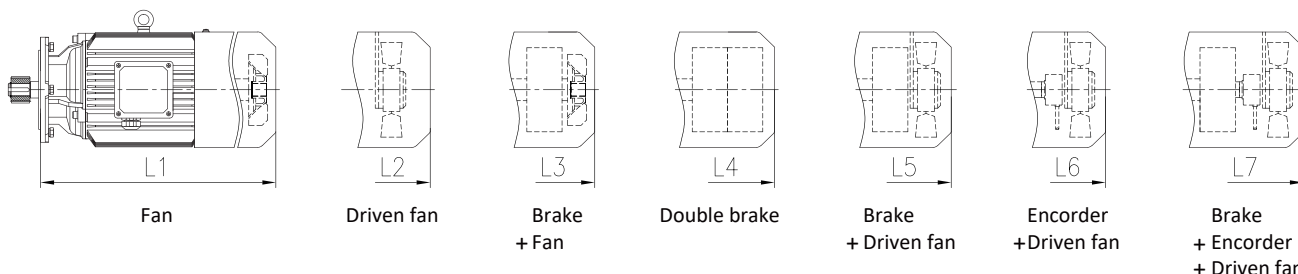

Directly connected motor dimension table

4-pole power (kW)	Range of Ratio	MS							MH							MP							MA							D
		L1	L2	L3	L4	L5	L6	L7	L1	L2	L3	L4	L5	L6	L7	L1	L2	L3	L5	L6	L7	L1	L2	L3	L5	L6	L7			
0.55	250-500	283	328	343	403	388	388	438	283	328	343	/	388	388	438	283	328	343	388	388	438	283	328	343	388	388	433	162		
0.75	180-500	283	328	343	403	388	388	438	283	328	343	/	388	388	438	283	328	343	388	388	438	283	328	343	388	388	433	162		
1.1	100-315	306	351	361	421	406	406	461	306	351	361	/	406	406	461	306	351	361	406	406	461	331	376	386	436	436	481	176		
1.5	50-315	306	351	361	421	406	406	461	306	351	361	/	406	406	461	331	376	386	431	431	486	331	376	386	436	436	481	176		
2.2	31.5-315	378	418	453	513	493	493	548	378	418	453	/	493	493	548	378	418	453	493	493	548	378	433	453	513	513	558	202		
3	25-250	378	418	453	513	493	493	548	378	418	453	/	493	493	548	378	418	453	493	493	548	378	433	453	513	513	558	202		
4	12.5-180	374	424	449	509	499	499	554	442	492	517	/	567	567	622	442	492	517	567	567	622	442	502	517	582	582	622	220		
5.5	10-100	413	463	493	558	538	538	593	413	463	493	/	538	538	593	451	501	531	576	576	631	489	554	569	639	639	669	259		
7.5	10-50	451	501	531	596	576	576	631	451	501	531	/	576	576	631	489	539	569	614	614	669	489	554	569	639	639	669	259		
11	10-31.5	/	541	601	/	631	631	681	506	541	601	651	631	631	681	550	585	645	675	675	725	550	600	645	700	700	735	314		
15	10-25	/	585	645	/	675	675	725	550	585	645	695	675	675	725	580	615	675	705	705	755	580	630	675	730	730	765	314		

Directly connected motor weight table / kg

4-pole power (kW)	Range of Ratio	MS							MH							MP							MA						
		M1	M2	M3	M4	M5	M6	M7	M1	M2	M3	M4	M5	M6	M7	M1	M2	M3	M5	M6	M7	M1	M2	M3	M5	M6	M7		
0.55	250-500	13	14	17	21	18	15	19	14	15	18	/	19	16	20	15	16	19	20	17	21	15	16	19	20	16.5	21		
0.75	180-500	14	15	18	22	19	16	20	15	16	19	/	20	17	21	16	17	20	21	18	22	16	17	20	21	17.5	22		
1.1	100-315	16	17	20	24	21	18	22	18	19	22	/	23	20	24	21	22	25	26	23	27	23	24	27	28	24.5	29		
1.5	50-315	17	18	21	25	22	19	23	19	20	23	/	24	21	25	23	24	27	28	25	29	23	24	27	28	24.5	29		
2.2	31.5-315	27	28	35	42	36	29	37	30	31	38	/	39	32	40	32	33	40	41	34	42	36	37	44	45	38	45		
3	25-250	30	31	38	45	39	32	40	33	34	41	/	42	35	43	36	37	44	45	38	46	36	37	44	45	38	45		
4	12.5-180	45	46	53	61	54	47	55	52	53	60	/	61	54	62	56	57	64	65	58	66	56	57	64	65	58	66		
5.5	10-100	63	65	74	85	76	66	77	67	69	78	/	80	70	81	77	79	88	90	80	91	88	90	99	101	91	102		
7.5	10-50	73	75	84	95	86	76	87	80	82	91	/	93	83	94	88	90	99	101	91	102	88	90	99	101	91	102		
11	10-31.5	/	123	142	/	143	124	144	121	123	142	162	143	124	144	129	131	150	151	132	152	129	131	150	151	132	152		
15	10-25	/	141	160	/	161	142	162	139	141	160	180	161	142	162	161	163	182	183	164	184	161	163	182	183	164	184		



S

S209 Dimensions

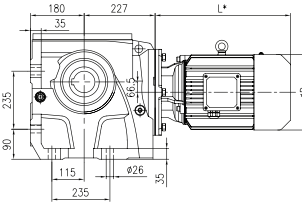
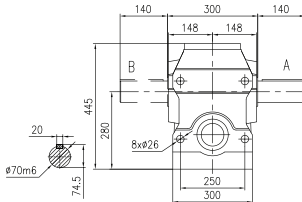
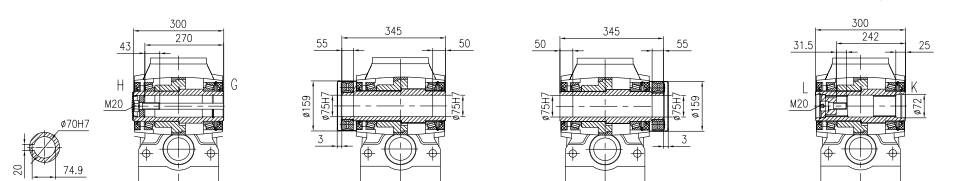
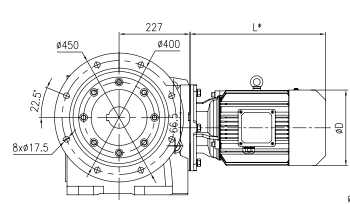
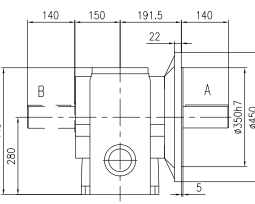
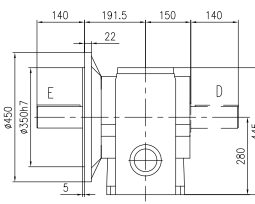
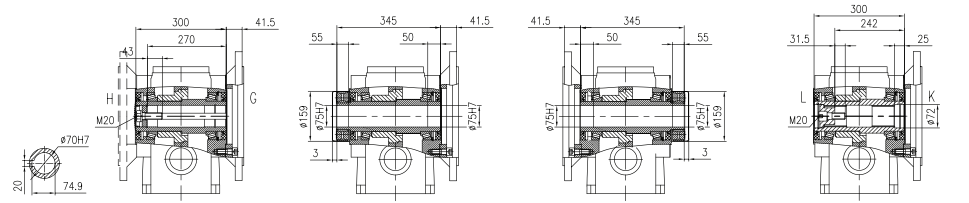
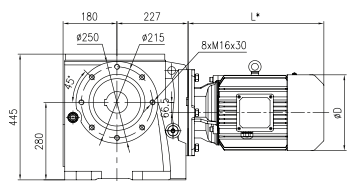
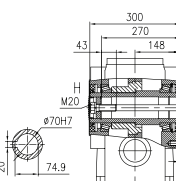
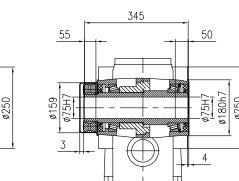
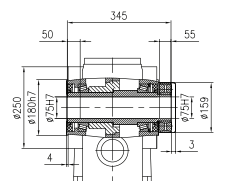
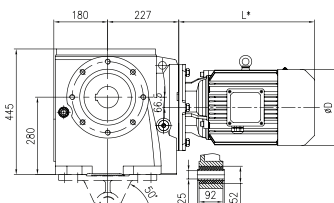
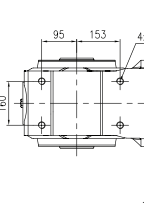
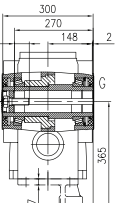
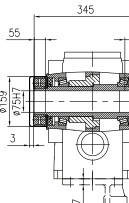
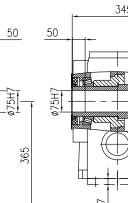
Mounting Mode	S209 Dimensions					
Horizontal foot-mounted	 <p>Horizontal foot-mounted (H) Weight: 150kg (Without motor and oil)</p>		 <p>S209HA Unidirectional output shaft S209HB Unidirectional output shaft S209HC Bidirectional output shaft</p>  <p>S209HG Hollow shaft with parallel key S209HH Hollow shaft with parallel key S209HI Hollow shaft with shrink disk S209HJ Hollow shaft with shrink disk S209HK Hollow shaft with involute spline S209HL Hollow shaft with involute spline</p>			
Flange-mounted	 <p>Flange-mounted (F) Weight: 175kg (Without motor and oil)</p>		 <p>S209FA Unidirectional output shaft S209FB Unidirectional output shaft S209FC Bidirectional output shaft</p>  <p>S209FD Unidirectional output shaft S209FE Unidirectional output shaft S209FF Bidirectional output shaft</p>  <p>S209FG Hollow shaft with parallel key S209FH Hollow shaft with parallel key S209FI Hollow shaft with shrink disk S209FJ Hollow shaft with shrink disk S209FK Hollow shaft with involute spline S209FL Hollow shaft with involute spline</p>			
Short flange-mounted	 <p>Short flange-mounted (S) Weight: 150kg (Without motor and oil)</p>		 <p>S209SG Hollow shaft with parallel key S209SH Hollow shaft with parallel key</p>  <p>S209SI Hollow shaft with shrink disk S209SJ Hollow shaft with shrink disk</p>  <p>S209SK Hollow shaft with involute spline S209SL Hollow shaft with involute spline</p>			
Torque arm-mounted	 <p>Torque arm-mounted with accessory (T) Weight: 165kg (Without motor and oil)</p>  <p>Torque arm-mounted without accessory (A) Weight: 150kg (Without motor and oil)</p>		 <p>S209AG Hollow shaft with parallel key S209AH Hollow shaft with parallel key S209AT Hollow shaft with parallel key</p>  <p>S209TI Hollow shaft with shrink disk S209TJ Hollow shaft with shrink disk</p>  <p>S209TK Hollow shaft with involute spline S209TL Hollow shaft with involute spline</p>			

Note: Involute spline size DIN 5480: m2×234×α30×D70×9H

Corresponding motor dimension table for S209

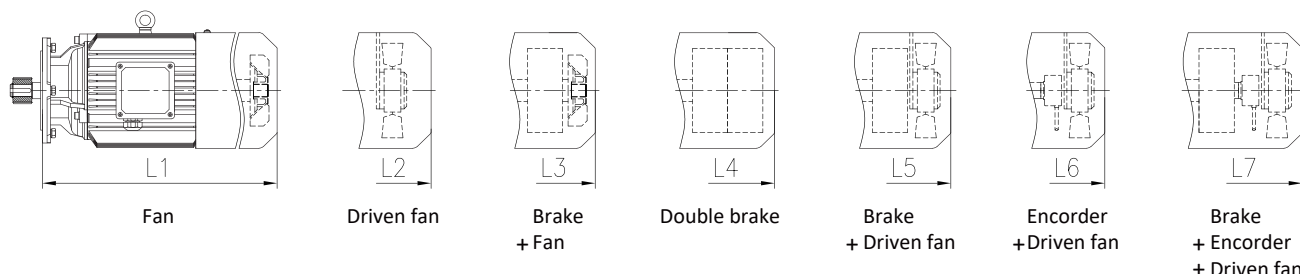

Directly connected motor dimension table

4-pole power (kW)	Range of Ratio	MS							MH							MP							MA							D
		L1	L2	L3	L4	L5	L6	L7	L1	L2	L3	L4	L5	L6	L7	L1	L2	L3	L5	L6	L7	L1	L2	L3	L5	L6	L7			
0.75	315-500	280	325	340	400	385	385	435	280	325	340	/	385	385	435	280	325	340	385	385	435	280	325	340	385	385	430	162		
1.1	224-315	303	348	358	418	403	403	458	303	348	358	/	403	403	458	303	348	358	403	403	458	328	373	383	433	433	478	176		
1.5	160-315	303	348	358	418	403	403	458	303	348	358	/	403	403	458	328	373	383	428	428	483	328	373	383	433	433	478	176		
2.2	90-315	374	414	449	509	489	489	544	374	414	449	/	489	489	544	374	414	449	489	489	544	374	429	449	509	509	554	202		
3	63-315	374	414	449	509	489	489	544	374	414	449	/	489	489	544	374	414	449	489	489	544	374	429	449	509	509	554	202		
4	40-315	370	420	445	505	495	495	550	438	488	513	/	563	563	618	438	488	513	563	563	618	438	498	513	578	578	618	220		
5.5	20-160	412	462	492	557	537	537	592	412	462	492	/	537	537	592	450	500	530	575	575	630	488	553	568	638	638	668	259		
7.5	18-160	450	500	530	595	575	575	630	450	500	530	/	575	575	630	488	538	568	613	613	668	488	553	568	638	638	668	259		
11	18-90	/	535	595	/	625	625	675	500	535	595	645	625	625	675	544	579	639	669	669	719	544	594	639	694	694	729	314		
15	18-63	/	579	639	/	669	669	719	544	579	639	689	669	669	719	574	609	669	699	699	749	574	624	669	724	724	759	314		
18.5	18-40	/	645	725	/	750	750	795	615	645	725	780	725	750	795	615	645	725	750	750	795	615	660	725	770	770	810	356		
22	18-31.5	/	693	773	/	798	798	843	663	693	773	828	773	798	843	663	693	773	798	798	843	663	708	773	818	818	858	356		

Directly connected motor weight table / kg

4-pole power (kW)	Range of Ratio	MS							MH							MP							MA						
		M1	M2	M3	M4	M5	M6	M7	M1	M2	M3	M4	M5	M6	M7	M1	M2	M3	M5	M6	M7	M1	M2	M3	M5	M6	M7		
0.75	315-500	14	15	18	22	19	16	20	15	16	19	/	20	17	21	16	17	20	21	18	22	16	17	20	21	17.5	22		
1.1	224-315	16	17	20	24	21	18	22	18	19	22	/	23	20	24	20	21	24	25	22	26	23	24	27	28	24.5	29		
1.5	160-315	17	18	21	25	22	19	23	19	20	23	/	24	21	25	22	23	26	27	24	28	23	24	27	28	24.5	29		
2.2	90-315	27	28	35	42	36	29	37	30	31	38	/	39	32	40	32	33	40	41	34	42	36	37	44	45	38	45		
3	63-315	30	31	38	45	39	32	40	33	34	41	/	42	35	43	36	37	44	45	38	46	36	37	44	45	38	45		
4	40-315	45	46	53	61	54	47	55	52	53	60	/	61	54	62	56	57	64	65	58	66	56	57	64	65	58	66		
5.5	20-160	63	65	74	85	76	66	77	67	69	78	/	80	70	81	77	79	88	90	80	91	88	90	99	101	91	102		
7.5	18-160	73	75	84	95	86	76	87	80	82	91	/	93	83	94	88	90	99	101	91	102	88	90	99	101	91	102		
11	18-90	/	123	142	/	143	124	144	121	123	142	162	143	124	144	129	131	150	151	132	152	129	131	150	151	132	152		
15	18-63	/	141	160	/	161	142	162	139	141	160	180	161	142	162	161	163	182	183	164	184	161	163	182	183	164	184		
18.5	18-40	/	184	214	/	215	185	217	182	184	214	246	215	185	217	200	202	232	233	203	235	200	202	232	233	203	235		
22	18-31.5	/	206	236	/	237	207	239	204	206	236	268	237	207	239	220	222	252	253	223	255	220	222	252	253	223	255		

Corresponding motor dimension table for S210

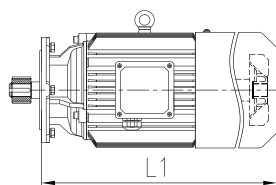

Fan

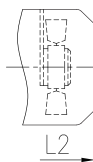

Driven fan

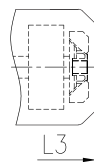

Brake
+ Fan

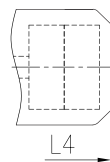

Double brake

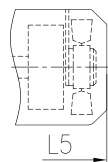

Brake
+ Driven fan

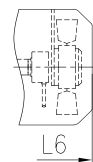

Encoder
+ Driven fan

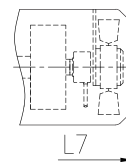

Brake
+ Encoder
+ Driven fan

Directly connected motor dimension table

4-pole power (kW)	Range of Ratio	MS							MH							MP							MA							D
		L1	L2	L3	L4	L5	L6	L7	L1	L2	L3	L4	L5	L6	L7	L1	L2	L3	L5	L6	L7	L1	L2	L3	L5	L6	L7			
1.5	250-400	300	345	355	415	400	400	455	300	345	355	/	400	400	455	325	370	380	425	425	480	325	370	380	430	430	475	176		
2.2	160-400	370	410	445	505	485	485	540	370	410	445	/	485	485	540	370	410	445	485	485	540	370	425	445	505	505	550	202		
3	100-400	370	410	445	505	485	485	540	370	410	445	/	485	485	540	370	410	445	485	485	540	370	425	445	505	505	550	202		
4	63-400	366	416	441	501	491	491	546	434	484	509	/	559	559	614	434	484	509	559	559	614	434	494	509	574	574	614	220		
5.5	40-224	401	451	481	546	526	526	581	401	451	481	/	526	526	581	439	489	519	564	564	619	477	542	557	627	627	657	259		
7.5	28-224	439	489	519	584	564	564	619	439	489	519	/	564	564	619	477	527	557	602	602	657	477	542	557	627	627	657	259		
11	18-160	/	524	584	/	614	614	664	489	524	584	634	614	614	664	533	568	628	658	658	708	533	583	628	683	683	718	314		
15	18-100	/	568	628	/	658	658	708	533	568	628	678	658	658	708	563	598	658	688	688	738	563	613	658	713	713	748	314		
18.5	18-71	/	634	714	/	739	739	784	604	634	714	769	714	739	784	604	634	714	739	739	784	604	649	714	759	759	799	356		
22	18-63	/	682	762	/	787	787	832	652	682	762	817	762	787	832	652	682	762	787	787	832	652	697	762	807	807	847	356		
30	18-35.5	/	710	820	/	825	825	870	705	710	820	845	825	825	870	705	710	820	825	825	870	705	725	820	845	845	890	398		

Directly connected motor weight table / kg

4-pole power (kW)	Range of Ratio	MS							MH							MP							MA						
		M1	M2	M3	M4	M5	M6	M7	M1	M2	M3	M4	M5	M6	M7	M1	M2	M3	M5	M6	M7	M1	M2	M3	M5	M6	M7		
1.5	250-400	17	18	21	25	22	19	23	19	20	23	/	24	21	25	23	24	27	28	25	29	23	24	27	28	24.5	29		
2.2	160-400	27	28	35	42	36	29	37	30	31	38	/	39	32	40	32	33	40	41	34	42	36	37	44	45	38	45		
3	100-400	30	31	38	45	39	32	40	33	34	41	/	42	35	43	36	37	44	45	38	46	36	37	44	45	38	45		
4	63-400	45	46	53	61	54	47	55	52	53	60	/	61	54	62	56	57	64	65	58	66	56	57	64	65	58	66		
5.5	40-224	63	65	74	85	76	66	77	67	69	78	/	80	70	81	77	79	88	90	80	91	88	90	99	101	91	102		
7.5	28-224	73	75	84	95	86	76	87	80	82	91	/	93	83	94	88	90	99	101	91	102	88	90	99	101	91	102		
11	18-160	/	123	142	/	143	124	144	121	123	142	162	143	124	144	129	131	150	151	132	152	129	131	150	151	132	152		
15	18-100	/	141	160	/	161	142	162	139	141	160	180	161	142	162	161	163	182	183	164	184	161	163	182	183	164	184		
18.5	18-71	/	184	214	/	215	185	217	182	184	214	246	215	185	217	200	202	232	233	203	235	200	202	232	233	203	235		
22	18-63	/	206	236	/	237	207	239	204	206	236	268	237	207	239	220	222	252	253	223	255	220	222	252	253	223	255		
30	18-35.5	/	260	310	/	308	261	310	260	260	310	360	308	261	310	280	280	330	328	281	330	280	280	330	328	281	330		



S

Mounting Mode	S212 Dimensions						
Horizontal foot-mounted	<p>Horizontal foot-mounted (H) Weight: 390kg (Without motor and oil)</p>		<p>S212HA Unidirectional output shaft S212HB Unidirectional output shaft S212HC Bidirectional output shaft</p>				
	<p>S212HG Hollow shaft with parallel key</p>	<p>S212HH Hollow shaft with parallel key</p>	<p>S212HI Hollow shaft with shrink disk</p>	<p>S212HJ Hollow shaft with shrink disk</p>	<p>S212HK Hollow shaft with involute spline</p>	<p>S212HL Hollow shaft with involute spline</p>	
Flange-mounted	<p>Flange-mounted (F) Weight: 425kg (Without motor and oil)</p>		<p>S212FA Unidirectional output shaft S212FB Unidirectional output shaft S212FC Bidirectional output shaft</p>		<p>S212FD Unidirectional output shaft S212FE Unidirectional output shaft S212FF Bidirectional output shaft</p>		
	<p>S212FG Hollow shaft with parallel key</p>	<p>S212FH Hollow shaft with parallel key</p>	<p>S212FI Hollow shaft with shrink disk</p>	<p>S212FJ Hollow shaft with shrink disk</p>	<p>S212FK Hollow shaft with involute spline</p>	<p>S212FL Hollow shaft with involute spline</p>	
Short flange-mounted	<p>Short flange-mounted (S) Weight: 390kg (Without motor and oil)</p>		<p>S212SG Hollow shaft with parallel key S212SH Hollow shaft with parallel key</p>	<p>S212SI Hollow shaft with shrink disk</p>	<p>S212SJ Hollow shaft with shrink disk</p>	<p>S212SK Hollow shaft with involute spline S212SL Hollow shaft with involute spline</p>	
Torque arm-mounted	<p>Torque arm-mounted with accessory (T) Weight: 415kg (Without motor and oil)</p>		<p>Torque arm-mounted without accessory (A) Weight: 390kg (Without motor and oil)</p>	<p>S212AG Hollow shaft with parallel key S212AH Hollow shaft with parallel key S212TG Hollow shaft with parallel key S212TH Hollow shaft with parallel key</p>	<p>S212AI Hollow shaft with shrink disk S212TI Hollow shaft with shrink disk</p>	<p>S212AJ Hollow shaft with shrink disk S212TJ Hollow shaft with shrink disk</p>	<p>S212AK Hollow shaft with involute spline S212AL Hollow shaft with involute spline S212TK Hollow shaft with involute spline S212TL Hollow shaft with involute spline</p>

Note: Involute spline size DIN 5480: m3×Z30×α30×D95×9H

Corresponding motor dimension table for S212

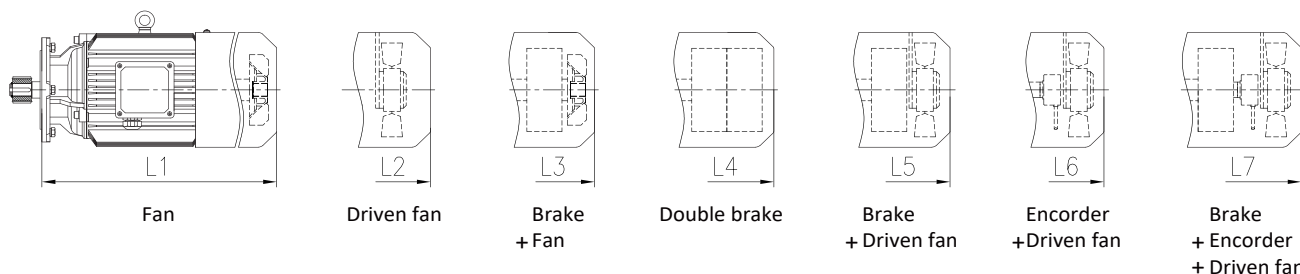

Directly connected motor dimension table

4-pole power (kW)	Range of Ratio	MS							MH							MP							MA							D
		L1	L2	L3	L4	L5	L6	L7	L1	L2	L3	L4	L5	L6	L7	L1	L2	L3	L5	L6	L7	L1	L2	L3	L5	L6	L7			
2.2	280-450	359	399	434	494	474	474	529	359	399	434	/	474	474	529	359	399	434	474	474	529	359	414	434	494	494	539	202		
3	200-450	359	399	434	494	474	474	529	359	399	434	/	474	474	529	359	399	434	474	474	529	359	414	434	494	494	539	202		
4	140-450	355	405	430	490	480	480	535	423	473	498	/	548	548	603	423	473	498	548	548	603	423	483	498	563	563	603	220		
5.5	100-250	391	441	471	536	516	516	571	391	441	471	/	516	516	571	429	479	509	554	554	609	467	532	547	617	617	647	259		
7.5	63-250	429	479	509	574	554	554	609	429	479	509	/	554	554	609	467	517	547	592	592	647	467	532	547	617	617	647	259		
11	35.5-250	/	508	568	/	598	598	648	473	508	568	618	598	598	648	517	552	612	642	642	692	517	567	612	667	667	702	314		
15	20-200	/	552	612	/	642	642	692	517	552	612	662	642	642	692	547	582	642	672	672	722	547	597	642	697	697	732	314		
18.5	18-160	/	618	698	/	723	723	768	588	618	698	753	698	723	768	588	618	698	723	723	768	588	633	698	743	743	783	356		
22	18-140	/	666	746	/	771	771	816	636	666	746	801	746	771	816	636	666	746	771	771	816	636	681	746	791	791	831	356		
30	18-80	/	689	799	/	804	804	849	684	689	799	824	804	804	849	684	689	799	804	804	849	684	704	799	824	824	869	398		
37	18-63	/	755	840	/	870	870	915	725	755	840	/	870	870	915	725	755	840	870	870	915	725	760	840	880	880	920	446		
45	18-45	/	755	840	/	870	870	915	725	755	840	/	870	870	915	725	755	840	870	870	915	725	760	840	880	880	920	446		
55	18-35.5	/	856	981	/	991	991	1026	841	856	981	/	991	991	1036	841	856	981	991	991	1036	841	866	981	1021	1021	1041	485		

Directly connected motor weight table / kg

4-pole power (kW)	Range of Ratio	MS							MH							MP							MA						
		M1	M2	M3	M4	M5	M6	M7	M1	M2	M3	M4	M5	M6	M7	M1	M2	M3	M5	M6	M7	M1	M2	M3	M5	M6	M7		
2.2	280-450	27	28	35	42	36	29	37	30	31	38	/	39	32	40	32	33	40	41	34	42	36	37	44	45	38	45		
3	200-450	30	31	38	45	39	32	40	33	34	41	/	42	35	43	36	37	44	45	38	46	36	37	44	45	38	45		
4	140-450	45	46	53	61	54	47	55	52	53	60	/	61	54	62	56	57	64	65	58	66	56	57	64	65	58	66		
5.5	100-250	63	65	74	85	76	66	77	67	69	78	/	80	70	81	77	79	88	90	80	91	88	90	99	101	91	102		
7.5	63-250	73	75	84	95	86	76	87	80	82	91	/	93	83	94	88	90	99	101	91	102	88	90	99	101	91	102		
11	35.5-250	/	123	142	/	143	124	144	121	123	142	162	143	124	144	129	131	150	151	132	152	129	131	150	151	132	152		
15	20-200	/	141	160	/	161	142	162	139	141	160	180	161	142	162	161	163	182	183	164	184	161	163	182	183	164	184		
18.5	18-160	/	184	214	/	215	185	217	182	184	214	246	215	185	217	200	202	232	233	203	235	200	202	232	233	203	235		
22	18-140	/	206	236	/	237	207	239	204	206	236	268	237	207	239	220	222	252	253	223	255	220	222	252	253	223	255		
30	18-80	/	260	310	/	308	261	310	260	260	310	360	308	261	310	280	280	330	328	281	330	280	280	330	328	281	330		
37	18-63	/	332	380	/	381	334	383	330	332	380	/	381	334	383	345	347	395	396	349	398	345	347	395	396	349	398		
45	18-45	/	347	395	/	396	349	398	345	347	395	/	396	349	398	365	367	415	416	369	418	365	367	415	416	369	418		
55	18-35.5	/	436	540	/	535	436	537	435	436	540	/	535	436	537	470	471	575	570	471	572	470	471	575	570	470	572		



8 Input Flange and Input Shaft

8.1 S series dimensions of AP input flange

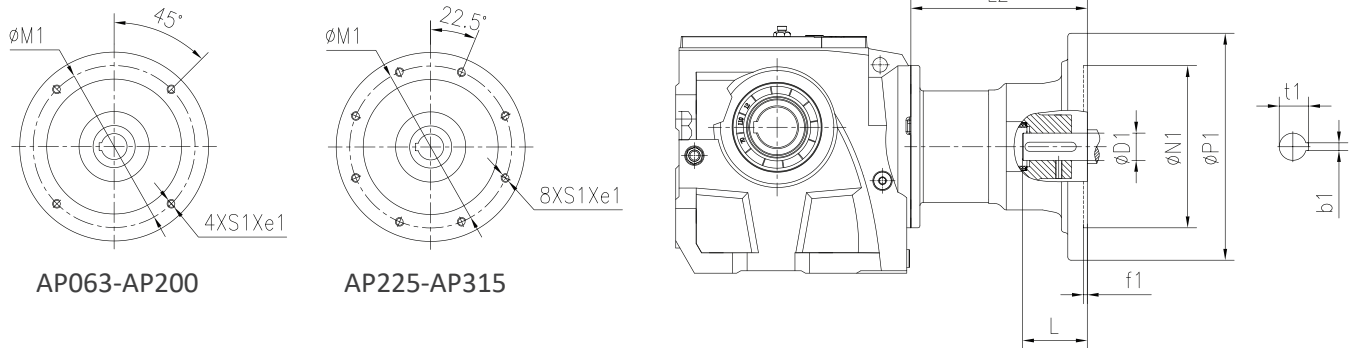

Size	Flange	Range of Ratio	e1	D1	N1	M1	P1	f1	b1	t1	L	S1	L2	Weight (kg)
S203	AP063	7.1-180	14	11H7	95H7	115	140	4	4	12.8	23	M8	59	4.8
	AP071	7.1-100	14	14H7	110H7	130	160	4	5	16.3	30	M8	59	4.8
	AP080	7.1-35.5	18	19H7	130H7	165	200	4	6	21.8	40	M10	74	7.6
S204	AP063	7.1-224	14	11H7	95H7	115	140	4	4	12.8	23	M8	59	4.8
	AP071	7.1-224	14	14H7	110H7	130	160	4	5	16.3	30	M8	59	4.8
	AP080	7.1-90	18	19H7	130H7	165	200	4	6	21.8	40	M10	74	7.6
S205	AP063	8-224	14	11H7	95H7	115	140	4	4	12.8	23	M8	61	5.1
	AP071	8-224	14	14H7	110H7	130	160	4	5	16.3	30	M8	61	5.1
	AP080	8-180	18	19H7	130H7	165	200	4	6	21.8	40	M10	76	8.6
	AP090	8-80	18	24H7	130H7	165	200	4	8	27.3	50	M10	81	9.2
	AP100	8-25	28	28H7	180H7	215	250	5	8	31.3	60	M12	191	14.1
S206	AP063	7.1-315	14	11H7	95H7	115	140	4	4	12.8	23	M8	61	5.1
	AP071	7.1-315	14	14H7	110H7	130	160	4	5	16.3	30	M8	61	5.1
	AP080	7.1-280	18	19H7	130H7	165	200	4	6	21.8	40	M10	76	8.6
	AP090	7.1-140	18	24H7	130H7	165	200	4	8	27.3	50	M10	81	9.2
	AP100	7.1-71	28	28H7	180H7	215	250	5	8	31.3	60	M12	191	14.1
	AP112	7.1-25	28	28H7	180H7	215	250	5	8	31.3	60	M12	191	14.1
S207	AP071	8-355	14	14H7	110H7	130	160	4	5	16.3	30	M8	53	6.7
	AP080	8-355	18	19H7	130H7	165	200	4	6	21.8	40	M10	68	10.3
	AP090	8-250	18	24H7	130H7	165	200	4	8	27.3	50	M10	73	11.1
	AP100	8-200	28	28H7	180H7	215	250	5	8	31.3	60	M12	181	15.5
	AP112	8-80	28	28H7	180H7	215	250	5	8	31.3	60	M12	181	15.5
	AP132	8-40	28	38H7	230H7	265	300	5	10	41.3	80	M12	210	22.3

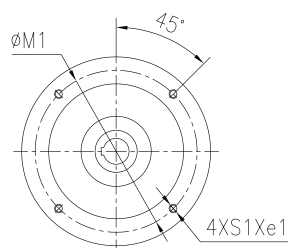

AP063-AP200

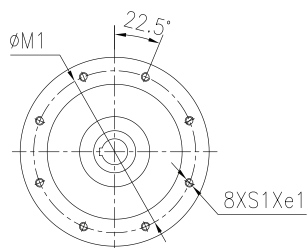

AP225-AP315

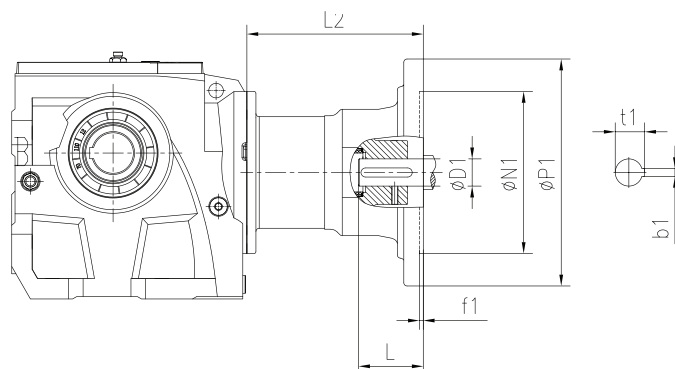

S

Size	Flange	Range of Ratio	e1	D1	N1	M1	P1	f1	b1	t1	L	S1	L2	Weight (kg)
S208	AP080	180-500	18	19H7	130H7	165	200	4	6	21.8	40	M10	65	10.4
	AP090	10-315	18	24H7	130H7	165	200	4	8	27.3	50	M10	66	12.1
	AP100	10-315	28	28H7	180H7	215	250	5	8	31.3	60	M12	171	18.2
	AP112	10-180	28	28H7	180H7	215	250	5	8	31.3	60	M12	171	18.2
	AP132	10-100	28	38H7	230H7	265	300	5	10	41.3	80	M12	203	24.9
	AP160	10-31.5	40	42H7	250H7	300	350	6	12	45.3	110	M16	272	46.4
S209	AP090	18-315	18	24H7	130H7	165	200	4	8	27.3	50	M10	70	14.7
	AP100	18-315	28	28H7	180H7	215	250	5	8	31.3	60	M12	172	21.5
	AP112	18-315	28	28H7	180H7	215	250	5	8	31.3	60	M12	172	21.5
	AP132	18-160	28	38H7	230H7	265	300	5	10	41.3	80	M12	202	28.3
	AP160	18-90	40	42H7	250H7	300	350	6	12	45.3	110	M16	270	49.9
	AP180	18-40	40	48H7	250H7	300	350	6	14	51.8	110	M16	270	49.9
S210	AP100	18-400	28	28H7	180H7	215	250	5	8	31.3	60	M12	162	25.6
	AP112	18-400	28	28H7	180H7	215	250	5	8	31.3	60	M12	162	25.6
	AP132	18-224	28	38H7	230H7	265	300	5	10	41.3	80	M12	189	33.7
	AP160	18-160	40	42H7	250H7	300	350	6	12	45.3	110	M16	257	52.3
	AP180	18-71	40	48H7	250H7	300	350	6	14	51.8	110	M16	257	52.3
	AP200	18-35.5	40	55H7	300H7	350	400	6	16	59.3	110	M16	327	77.4
S212	AP132	18-250	28	38H7	230H7	265	300	5	10	41.3	80	M12	175	46.4
	AP160	18-250	40	42H7	250H7	300	350	6	12	45.3	110	M16	243	66.9
	AP180	18-160	40	48H7	250H7	300	350	6	14	51.8	110	M16	243	66.9
	AP200	18-80	40	55H7	300H7	350	400	6	16	59.3	110	M16	316	89.8
	AP225	18-63	30	60H7	350H7	400	450	6	18	64.4	140	M16	343	97.5
	AP250	18-35.5	32	65H7	450H7	500	550	7	18	69.4	140	M16	361	131.3



8.2 S series dimensions of AS input flange

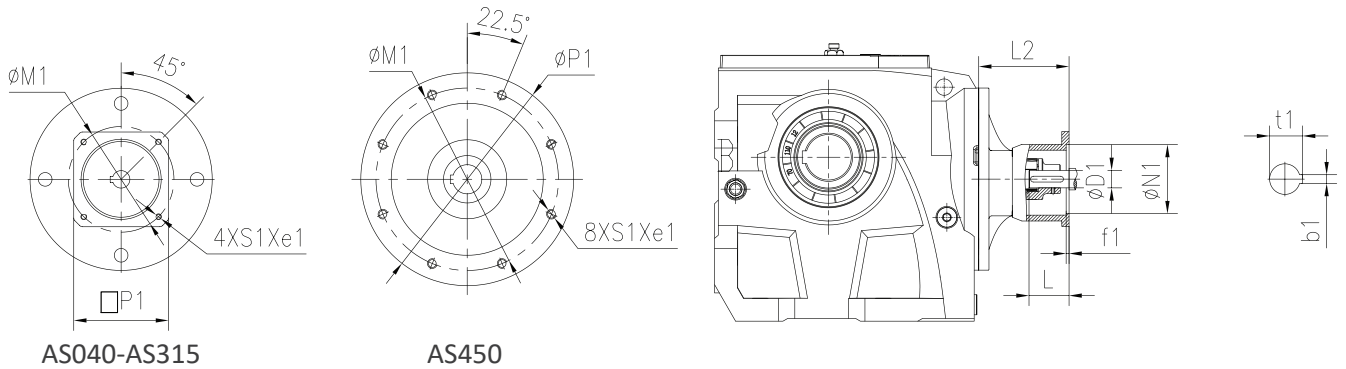

Size	Flange	Range of Ratio	e1	D1	N1	M1	P1	f1	b1	t1	L	S1	L2	eight (kg)
S203	AS040	7.1-180	4	8H7	30H7	46	78	4	2	9	25	M4	65	2.5
	AS055	7.1-180	4	9H7	40H7	63	78	4	3	10.4	25	M5	65	2.5
	AS060	7.1-180	10	14H7	50H7	70	60	4	5	16.3	30	M5	114	3.2
	AS070	7.1-180	10	14H7	60H7	75	70	4	5	16.3	30	M5	114	3.3
	AS080	7.1-180	10	19H7	70H7	90	80	4	6	21.8	35	M6	120	3.4
	AS090	7.1-180	10	19H7	80H7	100	90	4	6	21.8	40	M6	125	3.6
S204	AS040	7.1-224	4	8H7	30H7	46	78	4	2	9	25	M4	65	2.5
	AS055	7.1-224	4	9H7	40H7	63	78	4	3	10.4	25	M5	65	2.5
	AS060	7.1-224	10	14H7	50H7	70	60	4	5	16.3	30	M5	114	3.2
	AS070	7.1-224	10	14H7	60H7	75	70	4	5	16.3	30	M5	114	3.3
	AS080	7.1-224	10	19H7	70H7	90	80	4	6	21.8	35	M6	120	3.4
	AS090	7.1-224	10	19H7	80H7	100	90	4	6	21.8	40	M6	125	3.6
	AS100	7.1-125	14	19H7	95H7	115	100	4	6	21.8	45	M8	122	3.9
	AS125	7.1-125	15	24H7	110H7	130	130	5	8	27	50	M8	133	4.9
S205	AS140	7.1-125	15	24H7	110H7	145	130	5.5	8	27	55	M8	133	4.8
	AS060	8-224	10	14H7	50H7	70	60	4	5	16.3	30	M5	116	4.1
	AS070	8-224	10	14H7	60H7	75	70	4	5	16.3	30	M5	116	4.2
	AS080	8-224	10	19H7	70H7	90	80	4	6	21.8	35	M6	122	4.3
	AS090	8-224	10	19H7	80H7	100	90	4	6	21.8	40	M6	127	4.5
	AS100	8-180	14	19H7	95H7	115	100	4	6	21.8	45	M8	124	4.8
	AS125	8-180	15	24H7	110H7	130	130	5	8	27	50	M8	135	5.8
	AS140	8-180	15	24H7	110H7	145	130	5.5	8	27	55	M8	135	5.7
S206	AS160	8-180	15	32H7	130H7	165	155	5	10	35.3	60	M10	190	9.9
	AS060	7.1-315	10	14H7	50H7	70	60	4	5	16.3	30	M5	116	4.1
	AS070	7.1-315	10	14H7	60H7	75	70	4	5	16.3	30	M5	116	4.2
	AS080	7.1-315	10	19H7	70H7	90	80	4	6	21.8	35	M6	122	4.3
	AS090	7.1-315	10	19H7	80H7	100	90	4	6	21.8	40	M6	127	4.5
	AS100	7.1-200	14	19H7	95H7	115	100	4	6	21.8	45	M8	124	4.8
	AS125	7.1-200	15	24H7	110H7	130	130	5	8	27	50	M8	135	5.8
	AS140	7.1-200	15	24H7	110H7	145	130	5.5	8	27	55	M8	135	5.7
	AS160	7.1-200	15	32H7	130H7	165	155	5	10	35.3	60	M10	190	9.9

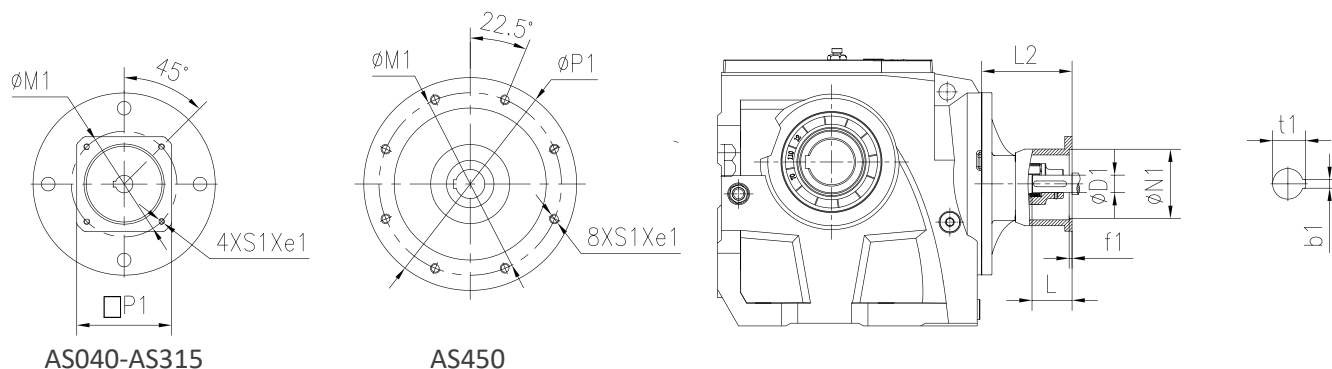

AS040-AS315

AS450

Size	Flange	Range of Ratio	e1	D1	N1	M1	P1	f1	b1	t1	L	S1	L2	Weight (kg)
S207	AS060	8-355	10	14H7	50H7	70	60	4	5	16.3	30	M5	108	5.6
	AS070	8-355	10	14H7	60H7	75	70	4	5	16.3	30	M5	108	5.7
	AS080	8-355	10	19H7	70H7	90	80	4	6	21.8	35	M6	114	5.8
	AS090	8-355	10	19H7	80H7	100	90	4	6	21.8	40	M6	119	6
	AS100	8-250	14	19H7	95H7	115	100	4	6	21.8	45	M8	116	6.3
	AS125	8-250	15	24H7	110H7	130	130	5	8	27	50	M8	127	7.3
	AS140	8-250	15	24H7	110H7	145	130	5.5	8	27	55	M8	127	7.2
	AS160	8-250	15	32H7	130H7	165	155	5	10	35.3	60	M10	180	11.3
	AS180	8-40	16	35H7	114.3H7	200	180	7	10	38.3	80	M12	210	16.7
	AS190	8-40	18	38H7	180H7	215	190	5	10	41.3	80	M12	210	17.1
AS240	8-40	28	38H7	230H7	265	240	5	10	41.3	80	M12	210	22.3	
S208	AS070	180-500	10	14H7	60H7	75	70	4	5	16.3	30	M5	105	8
	AS080	180-500	10	19H7	70H7	90	80	4	6	21.8	35	M6	111	8.1
	AS090	180-500	10	19H7	80H7	100	90	4	6	21.8	40	M6	116	8.3
	AS100	10-315	14	19H7	95H7	115	100	4	6	21.8	45	M8	113	8.6
	AS125	10-315	15	24H7	110H7	130	130	5	8	27	50	M8	124	9.6
	AS140	10-315	15	24H7	110H7	145	130	5.5	8	27	55	M8	124	9.5
	AS160	10-315	15	32H7	130H7	165	155	5	10	35.3	60	M10	170	14
	AS180	10-160	16	35H7	114.3H	200	180	7	10	38.3	80	M12	203	19.3
	AS190	10-160	18	38H7	180H7	215	190	5	10	41.3	80	M12	203	19.7
	AS240	10-160	28	38H7	230H7	265	240	5	10	41.3	80	M12	203	24.9
AS260	10-160	40	48H7	250H7	300	260	6	14	51.8	110	M16	272	46.4	
S209	AS160	18-315	15	32H7	130H7	165	155	5	10	35.3	60	M10	171	17.3
	AS180	18-160	16	35H7	114.3H	200	180	7	10	38.3	80	M12	202	22.7
	AS190	18-160	18	38H7	180H7	215	190	5	10	41.3	80	M12	202	23.1
	AS240	18-160	28	38H7	230H7	265	240	5	10	41.3	80	M12	202	28.3
	AS260	18-160	40	48H7	250H7	300	260	6	14	51.8	110	M16	271	49.9
S210	AS160	18-400	15	32H7	130H7	165	155	5	10	35.3	60	M10	161	21.4
	AS180	18-224	16	35H7	114.3H	200	180	7	10	38.3	80	M12	189	28.1
	AS190	18-224	18	38H7	180H7	215	190	5	10	41.3	80	M12	189	28.5
	AS240	18-224	28	38H7	230H7	265	240	5	10	41.3	80	M12	189	33.7
	AS260	18-224	40	48H7	250H7	300	260	6	14	51.8	110	M16	258	52.3
	AS315	18-40	40	55H7	300H7	350	315	6	16	59.3	110	M16	327	77.4
S212	AS180	18-250	16	35H7	114.3H	200	180	7	10	38.3	80	M12	175	40.8
	AS190	18-250	18	38H7	180H7	215	190	5	10	41.3	80	M12	175	41.2
	AS240	18-250	28	38H7	230H7	265	240	5	10	41.3	80	M12	175	46.4
	AS260	18-250	40	48H7	250H7	300	260	6	14	51.8	110	M16	244	66.9
	AS315	18-200	40	55H7	300H7	350	315	6	16	59.3	110	M16	316	89.8

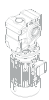

8.3 S series dimensions of AE input flange

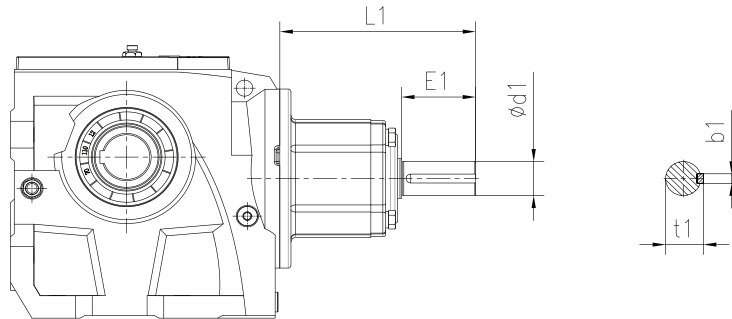

Size	Input Shaft	Range of Power	Range of Ratio	d1	E1	L1	b1	t1	Weight (kg)
S203	AE2	0.12-0.75 kW	7.1-180	19k6	40	117	6	21.5	2.5
S204	AE2	0.12-0.75 kW	7.1-224	19k6	40	117	6	21.5	2.5
S205	AE2	0.12-0.75 kW	8-224	19k6	40	119	6	21.5	3.4
	AE3	1.1-4 kW	8-80	28k6	60	175	8	31	6.1
S206	AE2	0.12-0.75 kW	7.1-315	19k6	40	119	6	21.5	3.4
	AE3	1.1-4 kW	7.1-140	28k6	60	175	8	31	6.1
S207	AE2	0.12-0.75 kW	71-355	19k6	40	111	6	21.5	4.9
	AE3	1.1-4 kW	8-250	28k6	60	165	8	31	7.5
	AE4	5.5-7.5 kW	8-40	38k6	80	211	10	41	10.5
S208	AE2	0.12-0.75 kW	180-500	19k6	40	108	6	21.5	7.2
	AE3	1.1-4 kW	10-315	28k6	60	155	8	31	10.2
	AE4	5.5-11 kW	10-100	38k6	80	204	10	41	13.1
	AE5	15-22 kW	10-25	42k6	110	266	12	45	23.3
S209	AE3	1.1-4 kW	18-315	28k6	60	156	8	31	10.2
	AE4	5.5-11 kW	18-160	38k6	80	203	10	41	13.1
	AE5	15-22 kW	18-63	42k6	110	265	12	45	23.3
S210	AE3	1.1-4 kW	18-400	28k6	60	146	8	31	17.6
	AE4	5.5-11 kW	18-224	38k6	80	190	10	41	21.9
	AE5	15-22 kW	18-100	42k6	110	252	12	45	29.2
	AE6	30-45 kW	18-35.5	48k6	110	309	14	51.5	45.5
S212	AE4	5.5-11 kW	18-250	38k6	80	176	10	41	34.6
	AE5	15-22 kW	18-200	42k6	110	238	12	45	43.8
	AE6	30-45 kW	18-80	48k6	110	298	14	51.5	57.9
	AE7	55-90 kW	18-35.5	55m6	110	297	16	59	64.6

9 Combi-type Dimensions

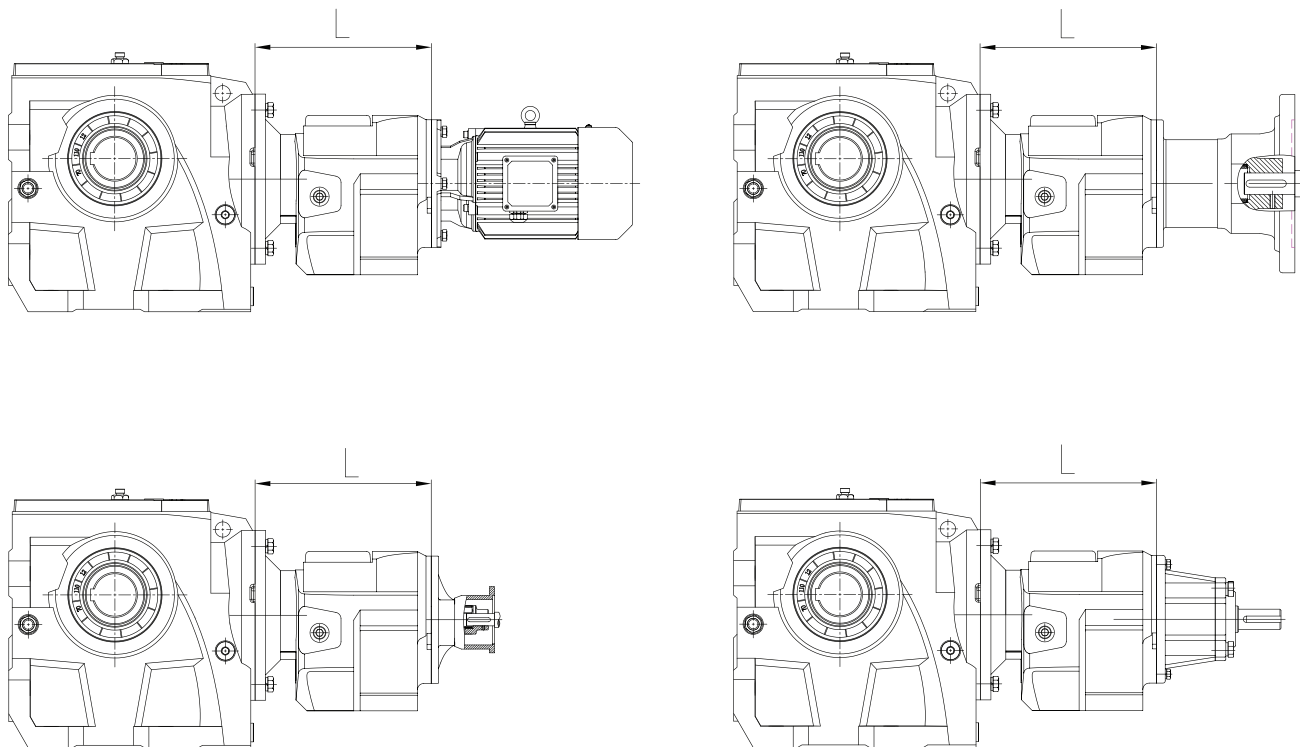

Type	S203/C201 S203/C301	S204/C201 S204/C301	S205/C203 S205/C303	S206/C203 S206/C303	S207/C203 S207/C303
L	134	134	170	170	170
Range of Motor Power (kW)	0.12-0.18	0.12-0.25	0.12-0.37	0.12-0.75	0.12-1.75
Type	S208/C205 S208/C305	S209/C205 S209/C305	S210/C207 S210/C307	S212/C307	S212/C208 S212/C308
L	182	182	226	226	264
Range of Motor Power (kW)	0.12-3	0.12-4	0.12-5.5	0.12-1.5	1.1-11



10 Motor Rainproof Cover Dimensions

S

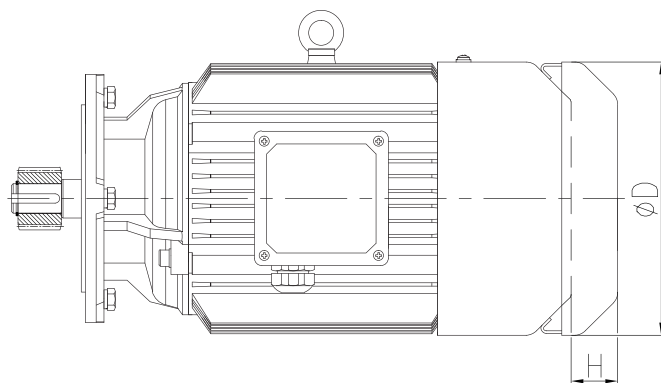

Frame Size	H63	H71	H80	H90	H100	H112	H132	H160	H180	H200	H225	H250	H280
D	124	139	159	176	199	220	259	314	356	398	446	485	547
H	20	25	25	30	35	35	40	55	60	65	70	75	80

11 Recommended Dimensions for Driven Equipment Shaft

11.1 Shrink disk

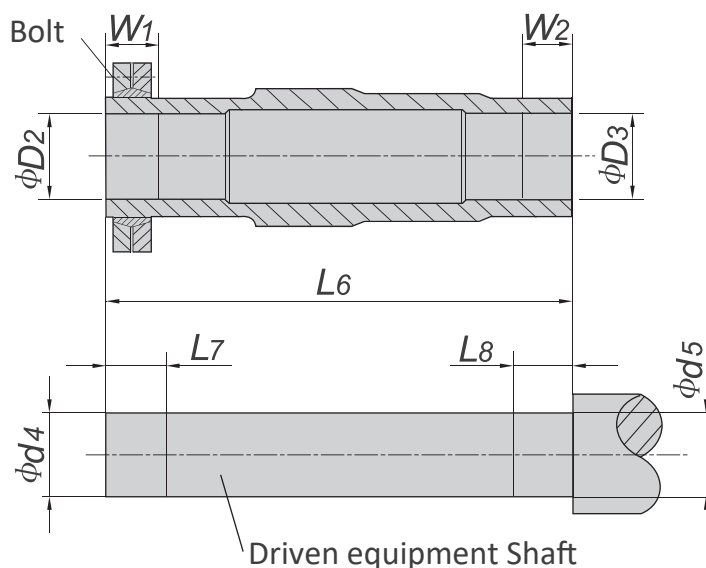

Size	D2	D3	d4	d5	L6	L7	L8	W1	W2	Type	Bolt	Weight
S203	25H7	25H7	25h6	25h6	145	40	40	35	35	SP2-36×72	M6	0.6
S204	25H7	25H7	25h6	25h6	145	40	40	35	35	SP2-36×72	M6	0.6
S205	35H7	35H7	35h6	35h6	177	35	25	30	20	SP2-44×80	M6	0.8
S206	40H7	40H7	40h6	40h6	208	43	25	38	20	SP2-50×90	M6	0.8
S207	50H7	50H7	50h6	50h6	241	41	35	36	30	SP2-62×110	M6	1.3
S208	65H7	65H7	65h6	65h6	281	46	45	41	40	SP2-80×145	M8	1.9
S209	75H7	75H7	75h6	75h6	345	60	55	55	50	SP2-90×155	M8	3.3
S210	95H7	95H7	95h6	95h6	405	75	70	65	60	SP2-110×185	M10	5.9
S212	105H7	105H7	105h6	105h6	485	95	80	85	70	SP2-140×230	M12	10

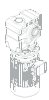

11.1 Involute spline

S

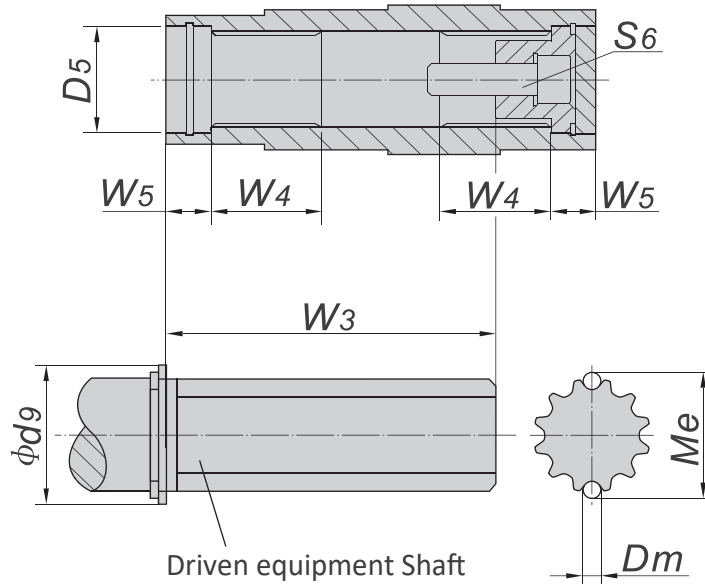

Size	D5	Dm	d9	Me	W3	W4	W5	S6
S203	32	2.25	37	20.28	90	25	18	M10×30
S204	32	2.25	37	20.28	90	25	18	M10×30
S205	37	3.5	42	27.71	115	32	18	M10×30
S206	42	3.5	47	27.71	140	42	25	M16×40
S207	55	3.5	62	42.62	160	52	23	M16×50
S208	72	3.5	82	57.65	180	62	25	M20×60
S209	72	3.5	90	62.66	240	72	25	M20×60
S210	90	5.25	105	73.92	290	89	26	M20×60
S212	100	5.25	120	84.11	380	92	28	M24×50

12 Shaft End Center Hole

Type C screw central hole in shaft end

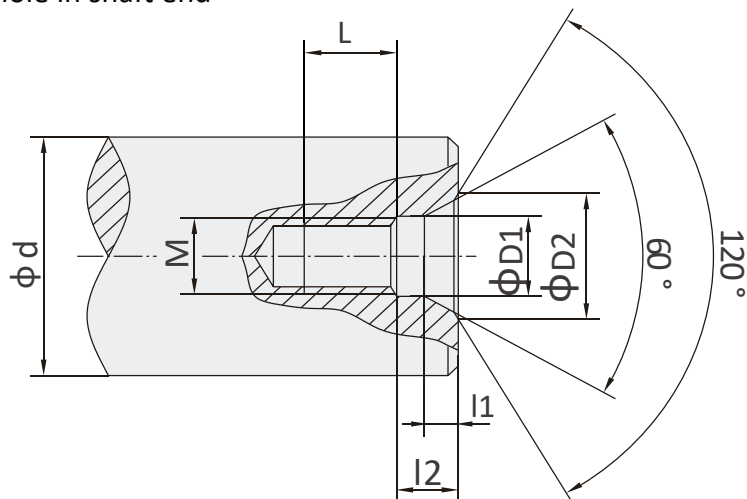

d	M	L	l2	l1	D1	D2
7<d≤10	M3	10	2.6	1.8	3.2	5.8
10<d≤13	M4	10	3.2	2.1	4.3	7.4
13<d≤16	M5	10	4	2.4	5.3	8.8
16<d≤21	M6	12	5	2.8	6.4	10.5
21<d≤24	M8	12	6	3.3	8.4	13.2
24<d≤30	M10	15	7.5	3.8	10.5	16.3
30<d≤38	M12	20	9.5	4.4	13	19.8
38<d≤50	M16	25	12	5.2	17	25.3
50<d≤85	M20	30	15	6.4	21	31.3
85<d≤130	M24	35	18	8	25	38
130<d≤225	M30	45	18	11	31	48



13 Dimension of Parallel Key and Keyway

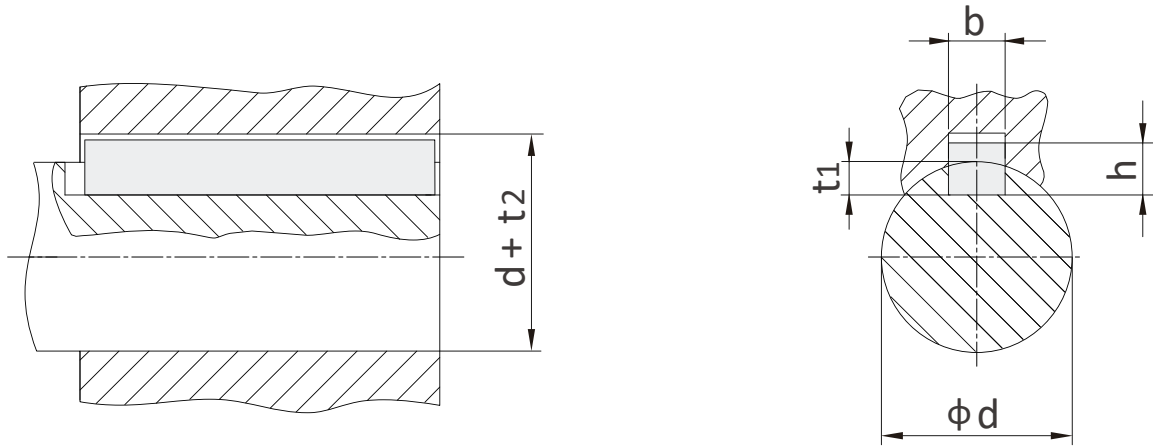

d	b	h	t ₁	d + t ₂
8 < d ≤ 10	3	3	1.8	d + 1.4
10 < d ≤ 12	4	4	2.5	d + 1.8
12 < d ≤ 17	5	5	3	d + 2.3
17 < d ≤ 22	6	6	3.5	d + 2.8
22 < d ≤ 30	8	7	4	d + 3.3
30 < d ≤ 38	10	8	5	d + 3.3
38 < d ≤ 44	12	8	5	d + 3.3
44 < d ≤ 50	14	9	5.5	d + 3.8
50 < d ≤ 58	16	10	6	d + 4.3
58 < d ≤ 65	18	11	7	d + 4.4
65 < d ≤ 75	20	12	7.5	d + 4.9
75 < d ≤ 85	22	14	9	d + 5.4
85 < d ≤ 95	25	14	9	d + 5.4
95 < d ≤ 110	28	16	10	d + 6.4
110 < d ≤ 130	32	18	11	d + 7.4
130 < d ≤ 150	36	20	12	d + 8.4
150 < d ≤ 170	40	22	13	d + 9.4
170 < d ≤ 200	45	25	15	d + 10.4
200 < d ≤ 230	50	28	17	d + 11.4
230 < d ≤ 260	56	32	20	d + 12.4

14 Oil

Size \ Mounting position	D1	D2	D3	D4	D5	D6
S203	0.3	0.5	0.6	0.7	0.5	0.5
S204	0.5	1.1	1.1	1.4	1.2	1.2
S205	0.6	1.4	1.2	1.9	1.7	1.7
S206	1.2	2.6	3.7	3.8	3.2	3.2
S207	2.3	5.0	7.0	7.8	5.9	5.9
S208	4.6	9.7	12.5	14.4	10.9	10.9
S209	8.9	18.0	22.6	28.3	21.6	21.6
S210	12.5	45.6	37.8	45.6	25.4	25.4
S212	22.0	80.4	63.6	80.4	42.8	42.8

S



Note:

- The structure scheme, appearance diagram and other attached diagrams in sample are examples, there is no strict proportion requirement. (The unmarked dimension units are mm).
- The marked weight is average value, it has no constraint force.

You must conform to the following instructions:

- To prevent accidents, all the rotation parts are added with protective covers according to the safety regulations of the nation and region.
- Before debugging, you should carefully read instruction book.
- Gearbox is on running-permission status when delivered, you should add lubrication oil before putting it into running.
- The marked oil quantity in sample is only reference value, actual oil filling quantity should be the same with the mark on oil immersion lens.
- Lubrication oil viscosity should be selected according to working situation and application environment temperature of gearmotor.
- You can only apply lubrication oil of internationally famous brand.

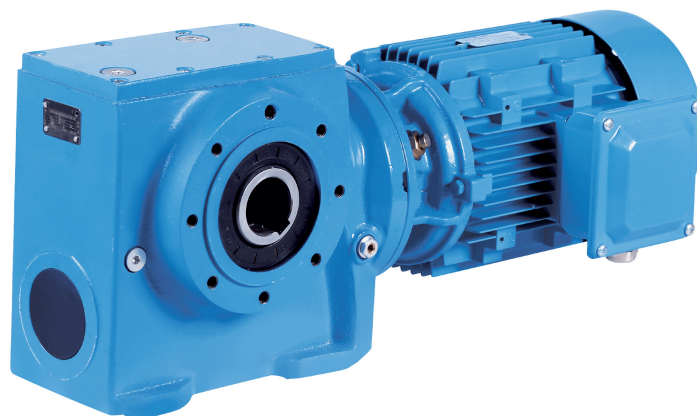



TGE Transmission s.r.o.

9. května 209,
268 01 Hořovice

Technical office Plzeň

Teslova 7b
301 00 Plzeň
info@tge.cz | www.tge.cz

Local dealer

