

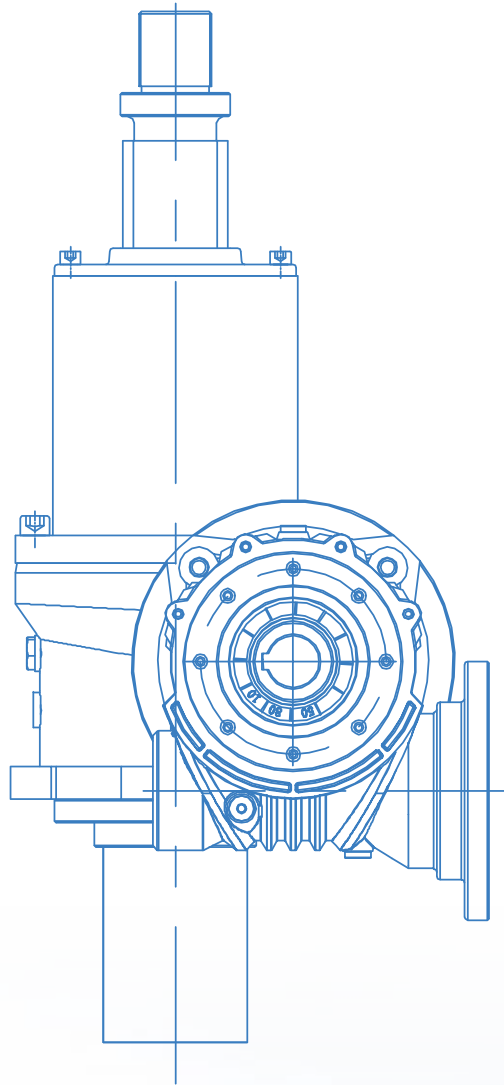

JB Ball Screw Jack

Modified date 08/2021



JB Ball Screw Jack

» On the basis of ball screw jack design and manufacturing experiences in the past twenty years,analyzing and absorbing advanced technology of international ball screw jack production,

» TGE Transmission makes innovative development, pushing forward new type JB ball screw jack to better satisfy customer requirements.

» Compared with internationally advanced ball screw jack and the original JWB ball screw jack of TGE, the new type JB ball screw jack.





1	Type designation	2
2	Structure scheme	3
3	Mounting positions	4
4	Basic Parameters	5
5	Type selection	6
6	Examples	15
7	Arrangement Type Examples	16
8	Examples Of Type Selection	17
9	Notes	19
10	Outline dimensions	20
11	Input modes	30
12	Direct Linking Input	30
13	Combined-type	31
14	Attachement	33

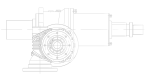

1 Type Designation

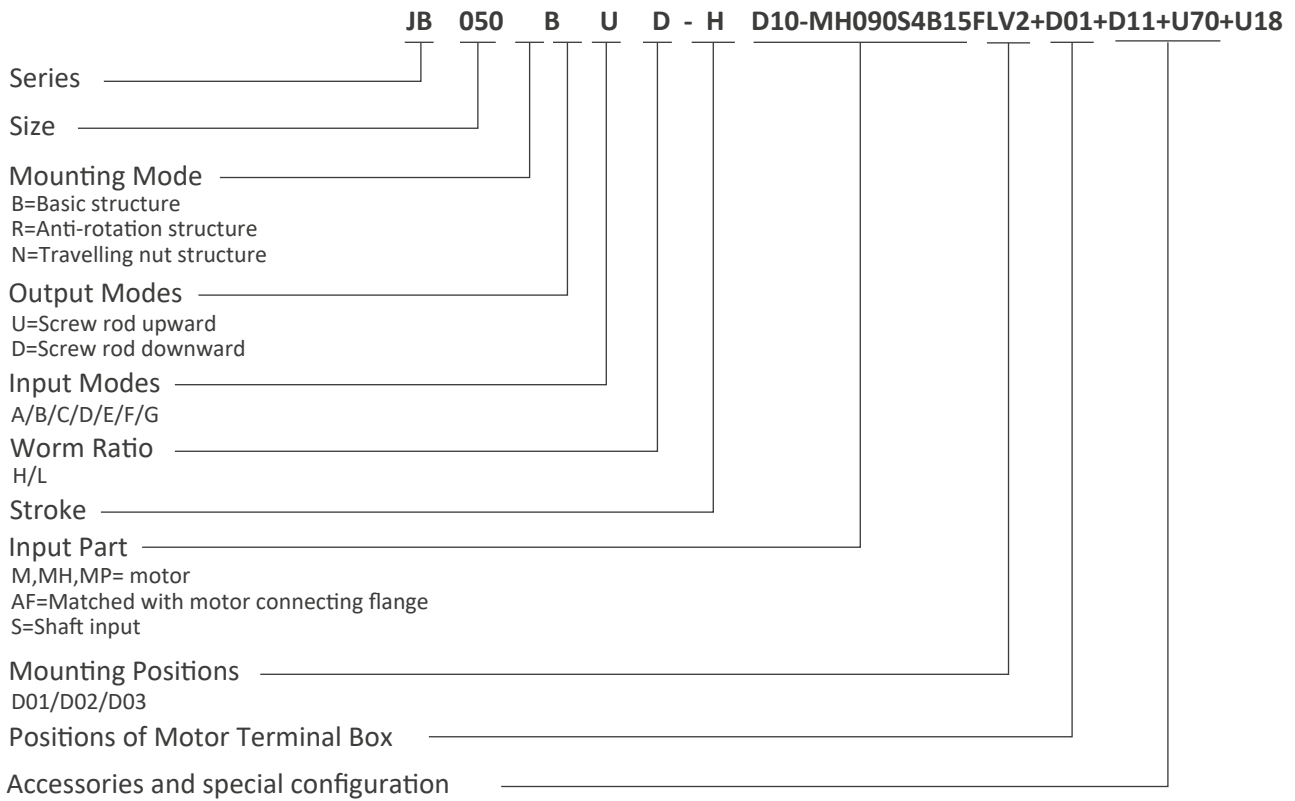

Combined-type Designation:JB100BUE-HD20-CRL37-18.9-M090S4B15ALV2+U14-D01-ZR01

Combined-type Designation:JB100BUE-HD20-R063FA-15-M090S4B15SLV2+U14-D01-ZR01

The code of screw stroke:

Code	Stroke	Code	Stroke	Code	Stroke
D10	100	D50	500	E12	1200
D20	200	D60	600	E15	1500
D30	300	D80	800	E20	2000
D40	400	E10	1000		

2 Structure Schemam

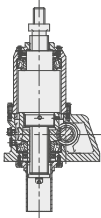
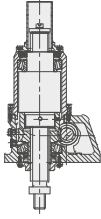
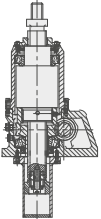
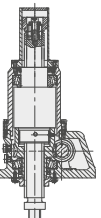
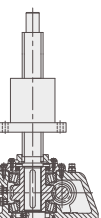
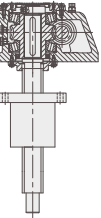
Structure Mode	Output Mode	Structure Drawing	Explanation
Plain mode	JB ..BU		The screw may produce rotary force when lifting,so anti-rotation measures should be adopted.
	JB ..BD		
With Anti-rotation device	JB ..RU		With anti-rotation device,the screw travels up and down only and produces no rotary force.
	JB ..RD		
Structure Traveling nut	JB ..NU		For travelling nut type,the screw rotates to drive the nut move.Due to its cylindric structure,supporting mode is often used at the screw end to ensure good transmission of long stroke.
	JB ..ND		Note:Bellows are not supplied with the travelling nut type screw jack.Consult us if required.

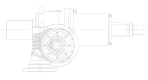

3 Mounting Positions

D1	
D2	
D3	

⚠ Note: When applying D3 mounting position, performance level of foot-mounting bolts should be above 10.9.

Motor terminal box and cable entry position:

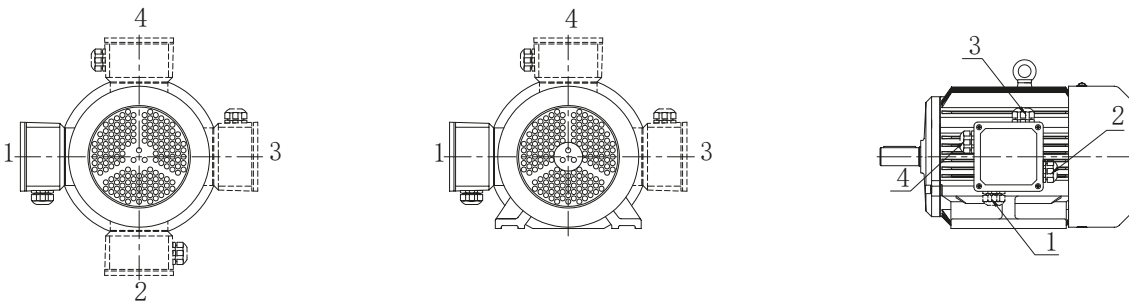

View: Motor after body

Assembly colour of jack JB010-JB500 (RAL5015)

4 Basic Parameters

Type		JB010	JB025	JB050	JB100	JB200	JB300	JB500
Maximum loading (KN)		9.8	24.5	49	98	196	294	490
Screw rod external diameter (mm)		20	25	40	50	63	80	100
Screw rod bottom diameter (mm)		16.2	19.3	32.4	41.4	54.4	68.6	88
Screw rod bolt distance L1(mm)		5	8	10	12	12	16	20
Ratio	H Speed	5	5.6	5.2	10.667	9.667	10.667	10.333
	L Speed	20	26	26	24	29	32	31
Comprehenswe efficiency % η	H Speed	61	62	64	63	62	56	60
	L Speed	34	35	39	43	41	34	38
Allowable input maximum Power (KW)	H Speed	0.54	1.3	2.21	2.97	4.87	8.49	12.78
	L Speed	0.27	0.61	0.95	1.87	2.59	3.70	6.37
Empty-loading torque T0	(N·m)	0.29	0.62	1.37	1.96	3.92	9.81	19.6
Holding torque (N·m)	H Speed	1.27	4.31	10.78	19.6	51.0	68.6	140.1
	L Speed	0.26	0.91	2.4	5.8	15.0	19.5	41.2
Allowable input shaft torque*	(N·m)	20	49	126	247	247	620	973
Input shaft torque for** Maximum loading (N·m)	H Speed	2.85	9.60	24.80	29.81	66.38	135.1	271.2
	L Speed	1.44	4.05	9.06	20.1	35.4	78.6	152.0
Screw movement per revolution of input shaft (mm)	H Speed	1.0	1.43	1.92	1.12	1.24	1.50	1.94
	L Speed	0.25	0.31	0.38	0.50	0.41	0.50	0.65
Allowable input shaft rotation speed(rpm) for maximum loading	H Speed	1500	1300	850	950	700	600	450
	L Speed	1500	1450	1000	890	700	450	400
Screw rod rotation torque during maximum loading	(N·m)	8.7	34.3	87.9	211.9	438.5	867.2	1806.7
Pipe material/	Stainless steel (anti-rotation pipe: common steel pipe)							
Lubrication mode/	Screw:Grease Worm gesr:Worm gear oil							
Cooling method/	Natural cooling							
Common ambient condition	Ambient temperature: $-10^{\circ}\text{C}\sim 40^{\circ}\text{C}$, open site has good ventilation, altitude is under 1000 meters, common plant dust.							
Specied ambient condition	High temperature, low temperature, much dust, chemical effect (acid,alkali,etc), oper-air (direct sunshine,ice,water spray,etc), please consult.							

** Allowable torque of input shaft of the gear unit.

*** Include non-loading torque value.

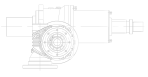

5 Type Selection

5.1 Determination of screw jack type

(1) Calculation of total equivalent load W_s (N)

$$W_s = W_{\max} \cdot f_1 (N)$$

Driven Machine Factor:

Load Characteristic	Example	Factor for driven machine
Uniform load, small inertia	Shifting device for switches, valves and conveyors	$1.0 < f_1 \leq 1.3$
Moderate shock load, medium inertia	Moving devices and elevators	$1.3 < f_1 \leq 1.5$
Heavy shock load, large inertia	Transport goods with trolley; keep the positions of calendaring roller	$1.5 < f_1 \leq 3.0$

(2) Calculation of equivalent load of single jack W (N):

$$W = \frac{W_s}{\text{Arrangement factor} \cdot \text{Number of jacks in arrangement} \cdot f_d}$$

Arrangement factor (f_d)

Number of jacks in arrangement	1	2	3	4	5~8
Arrangement factor	1	0.95	0.9	0.85	0.8

(3) Initial selection of jack type

Make an initial selection of jack type by fully considering load, speed, travel, efficiency and drive source.

(4) Make final determination of screw jack type in view of stroke, ambient environment and top end fittings.

5.2 Verification of input power

If the input power required is greater than the permissible input power, increase the size of the screw jack or decrease the speed of the screw.

Calculation of input power required:

Input speed required	n (r / min)	$n = \frac{V}{L_1} \cdot i$
Input torque required	T (N·m)	$T = \frac{W \times L_1}{2\pi \times i \times \eta} + T_0$
Input power required	P (kW)	$P = \frac{T \times v \eta}{9550}$

V : Elevator screw shaft (flexible nut) lifting speed (m/min)

L_1 : Screw rod pitch (m) i : Ratio

W : Equivalent load of single elevator (N) π : Circular constant

η : Comprehensive efficiency of elevator T_0 : Empty loading torque (N·m)

(L_1, i, η, T_0 Refer to basic foundation table)

5.3 Verification of the screw stability

Verify the screw stability when the axial compression load exists. If the load is greater than the critical load, increase the sizes before calculation.

The critical load is calculated with the following formula:

$$P_{CR} = f_m \times \left(\frac{d^2}{L_a} \right)^2 \quad \text{ensure} \quad P_{CR} > W \times S_F (S_F = 4)$$

JB

PCR: critical load

d: screw root diameter mm(see the table of technical data)

f_m: support factor

L_a: distance between action points, mm

W: equivalent load of single jack(N)

SF: safety factor(generally SF=4)

For verification of the screw stability, choose L_a(based on the sizes) and f_m (support factor) as follows

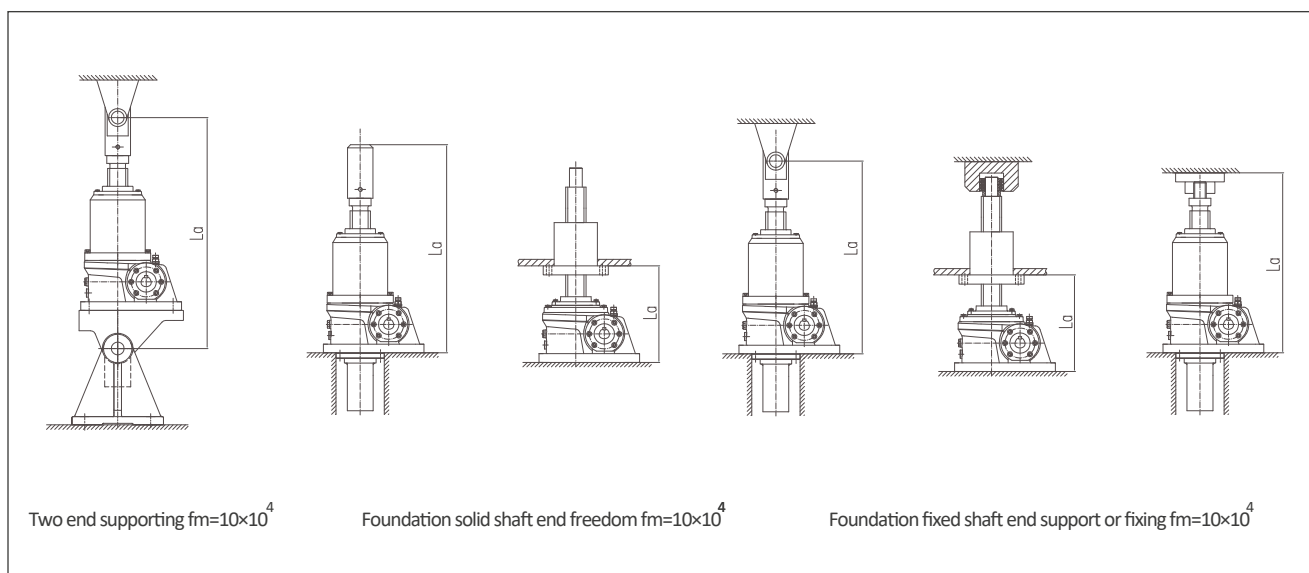

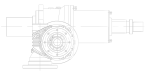

Associated diagram of allowed loading of point distance :

JB

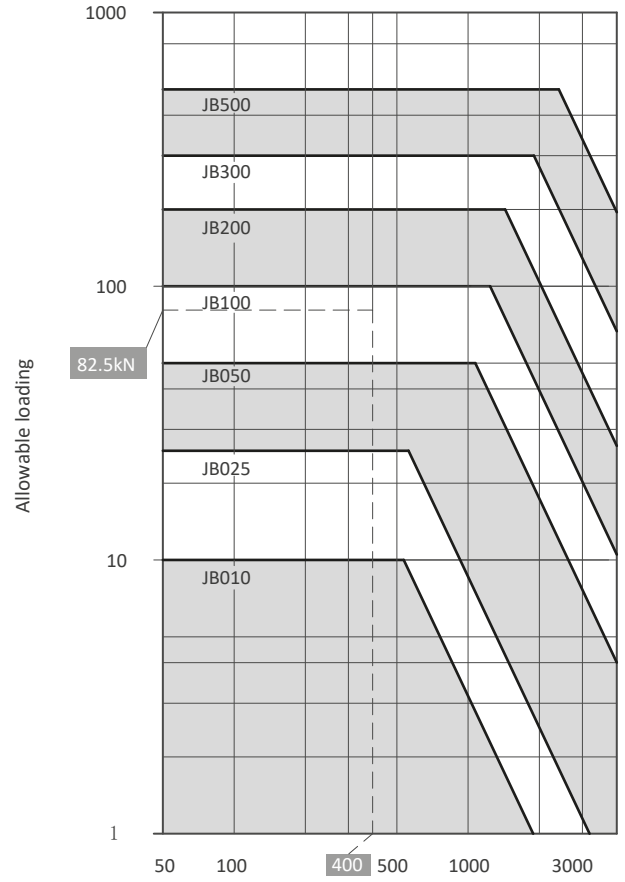
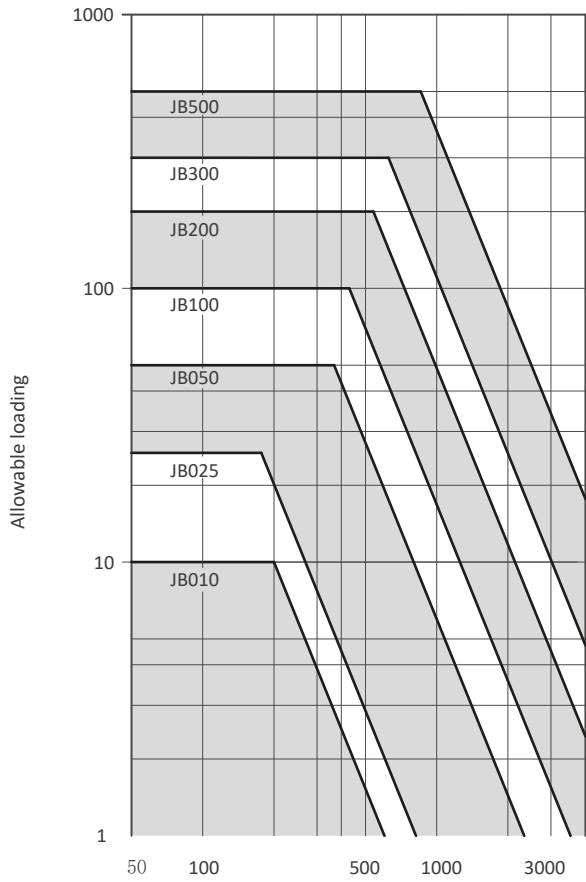

Distance between action points La mm (fm=20×10⁴)

Distance between action points La mm (fm=2.5×10⁴)

Means loading W=82.5kN, (safety coefficient SF=4) point distance La=400mm (foundation fixed shaft end supporting fixing fm=20×10⁴) as an example; at this time, you can select ladder screw elevator JB100 witch can satisfy crossing point of vertical and horizontal axis.

5.4 Verification of critical speed:

If select travelling nut type, the rotary speed of the screw must be lower than the critical speed; if vice versa, increase the size before calculation.

$$n_c = \frac{96 \times f_n \times d \times 10^6}{L_b^2} \qquad n_s = \frac{n_1}{i}$$

JB

n_c : critical speed r/min

d : screw root diameter mm(see the table of basic parameters)

f_n : length factor

L_b : distance between supports, mm

n_s : screw speed

n_1 : input speed r/min

i : ratio(see the table of basic parameters)

L_b (as per the sizes) and f_n (length factor) are as follows in verifying the rotary speed of screw.

Supporting shaft end $f_n=1.56$

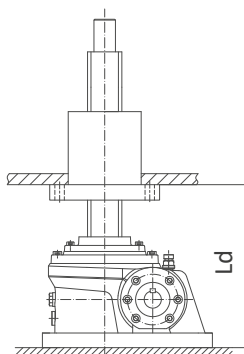

Movable shaft end $f_n=0.36$

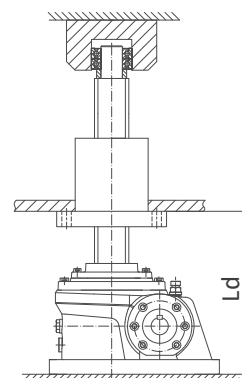

Calculation example: JB200NUA-HE12-D10N0-S Input speed is 1200r/min, run under shaft end support, check according to outline dimension and transmission capacity:

$i=9.667$ $d=54.4$ $L_b=1419$ E12:1200stroke

$$n_s = \frac{n_1}{i} = \frac{1200}{9.667} = 124 \text{ r/min}$$

$$n_c = \frac{96 \times f_n \times d \times 10^6}{L_b^2} = \frac{96 \times 1.56 \times 54.4 \times 10^6}{(1419)^2} = 4046 \text{ r/min}$$

$$n_c = 4046 \text{ r/min} > 124 \text{ r/min} \dots\dots\dots \text{ok}$$

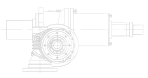

Association diagram of screw rod lifting speed and allowable loading:

The picture is established according to maximum allowable input capacity of screw rod, please check allowable loading according to this picture, determine elevator type. When detailed type is needed, confirm by calculation.

H Speed

JB

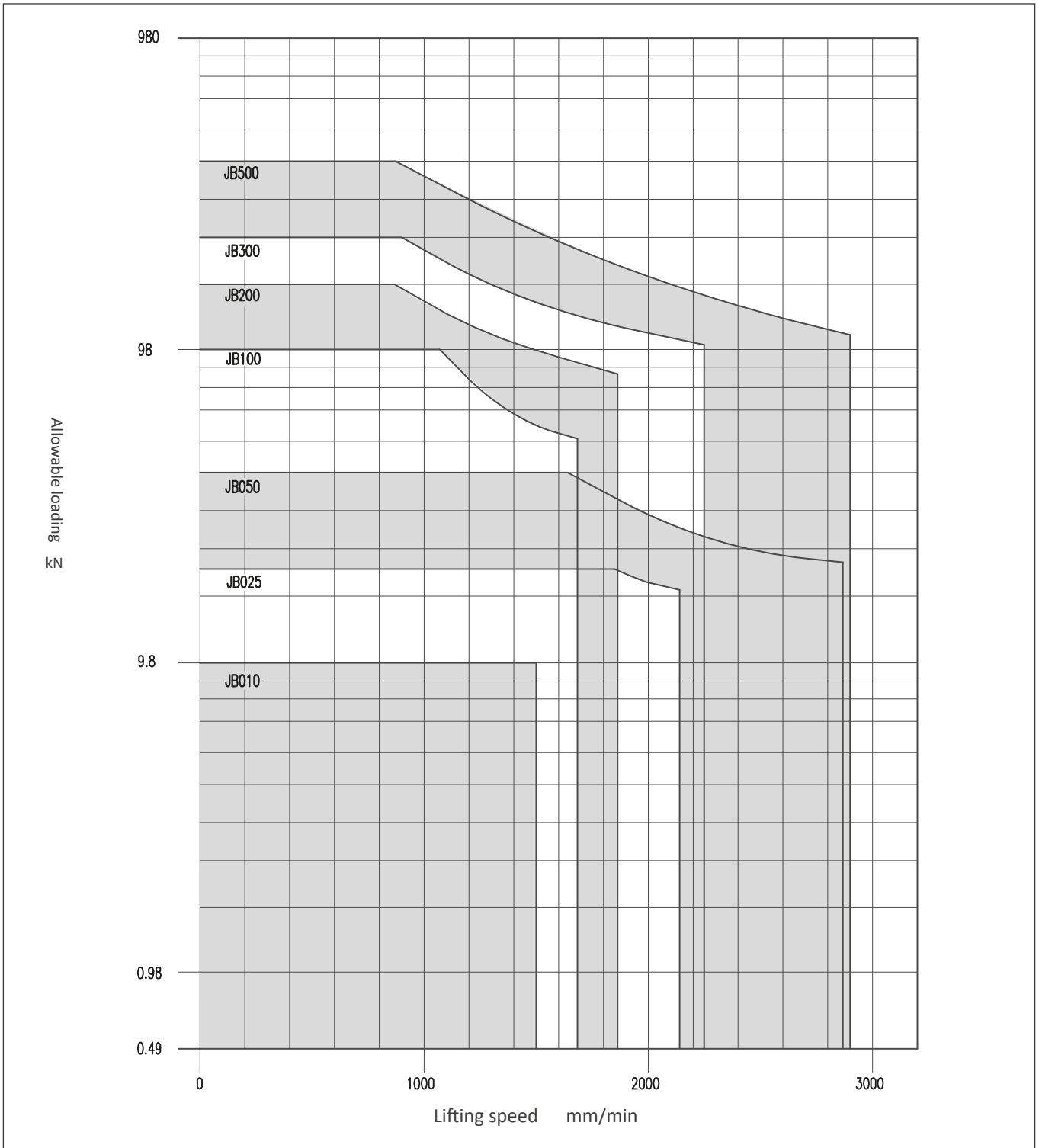

L Speed

JB

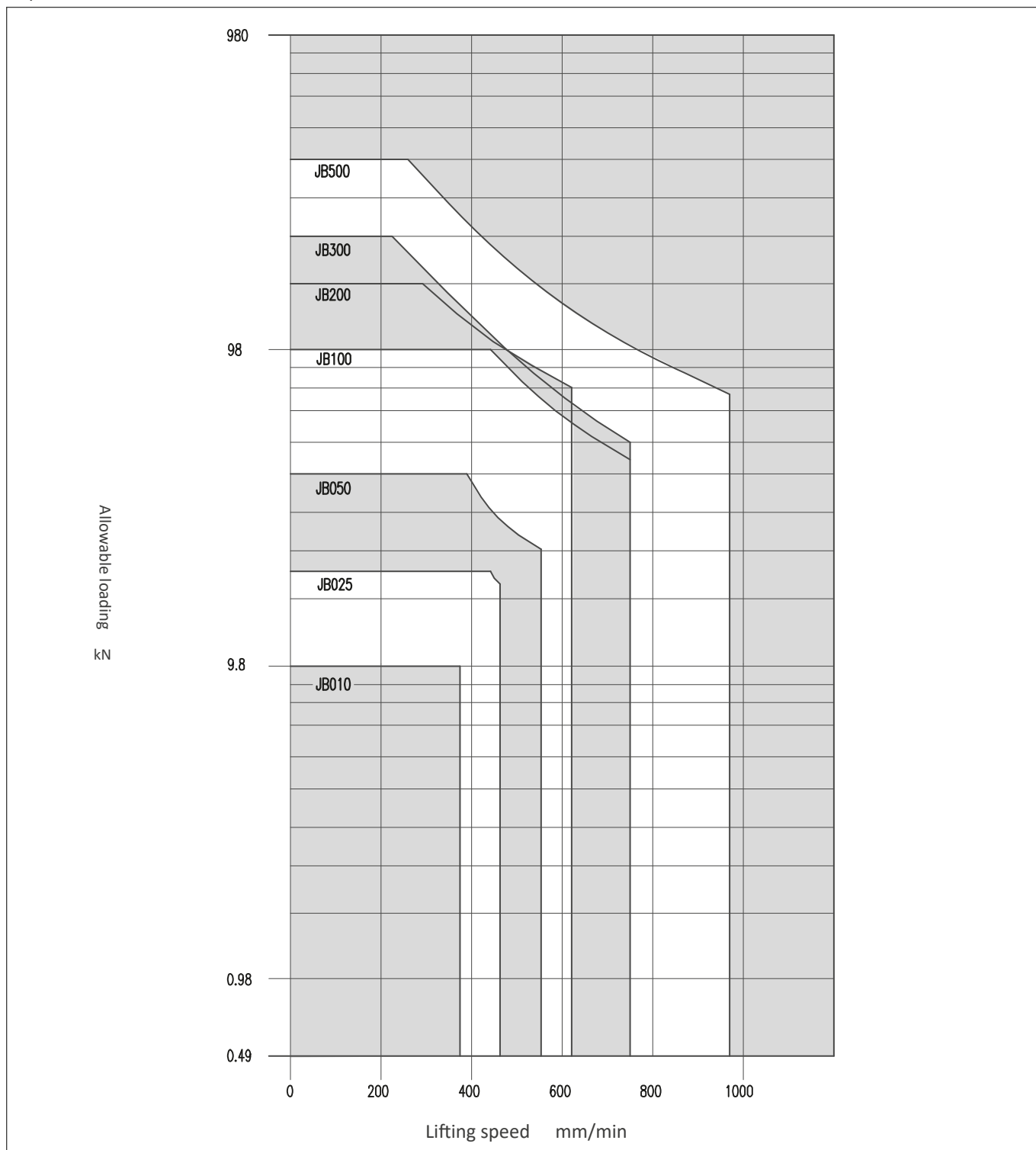

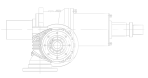

5.5 Drive source options

Determine the required drive unit capacity for synchronous drive Pt

1. Add the torque required for each jack T_{1-4} on the drive unit side to determine the overall torque T_t

(1) Required torque per jack:

$$T_{1-4} = \frac{T}{\text{Gearbox efficiency} \times \text{No. of gearbox}}$$

(2) Required torque for the drive unit:

$$T_t = T_1 + T_2 + T_3 + T_4$$

T_{1-4} : Required torque for each jack on the drive unit side N.m

T : Required input torque per jack N.m

T_t : Required torque for the drive unit N.m

Gearbox efficiency: Assume 0.9

For a four unit system (fig.1), $T_{1-4} = \frac{T}{0.9^2}$

fig.1

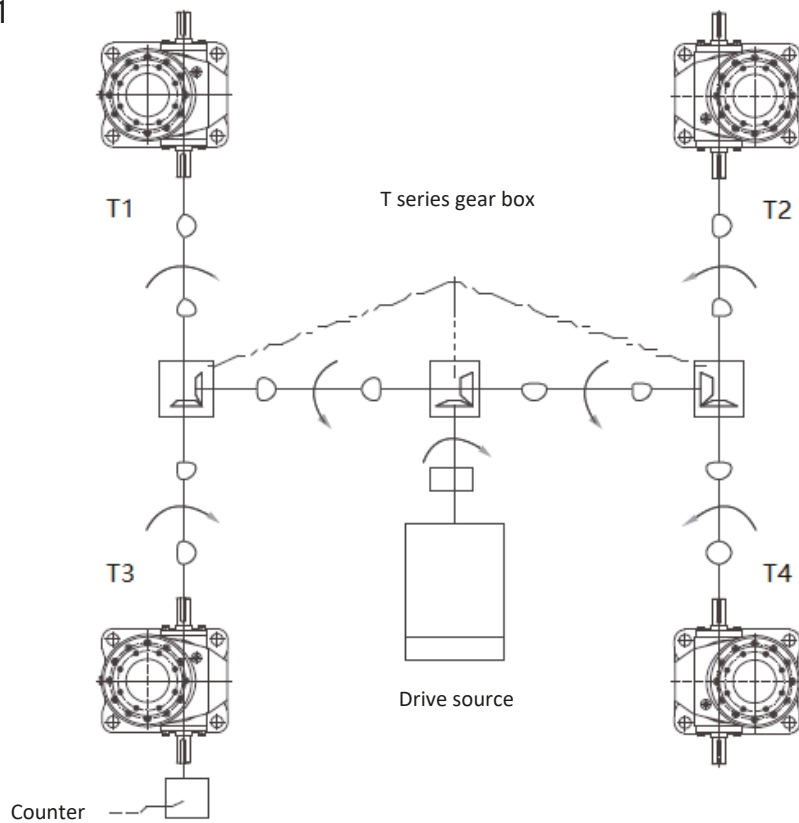

2. Determine the required drive unit capacity P_t with input n and overall T_t determined in 1.

$$P_t = \frac{T_t \times n}{9550}$$

5.6 Allowable radial force of input shaft Fr1

When installing chain wheel, gear, belt on input shaft, please confirm radial force exerted on input shaft is under allowable radial force.

Ratio	Allowable radial force Fr1							Unit (N)
	JB010	JB025	JB050	JB100	JB200	JB300	JB500	
H Speed	380	710	1500	2270	4320	6110	10100	
L Speed	220	420	820	1430	2800	4400	6650	

JB

5.7 Allowable radial force of screw rod output end Fr2

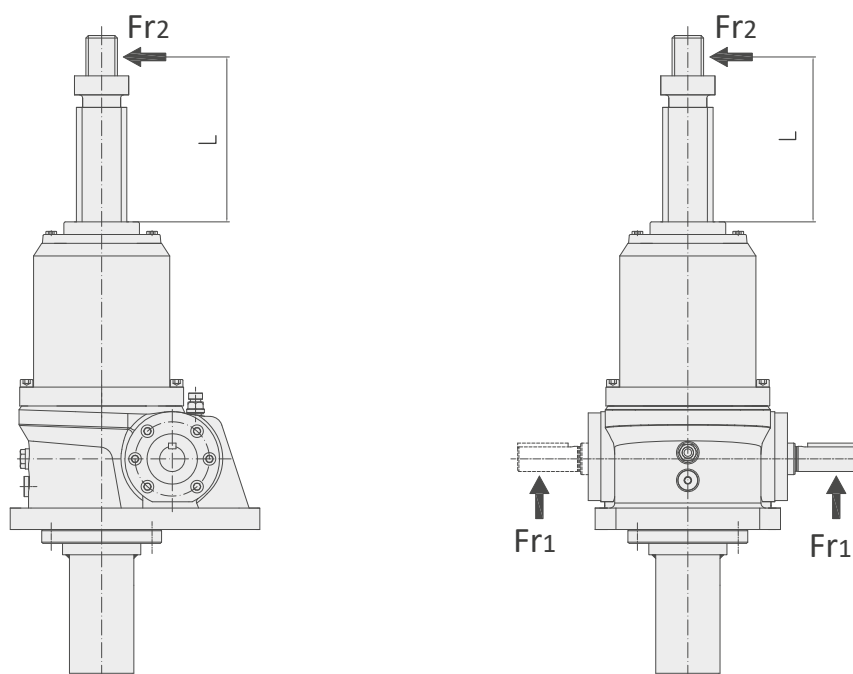

When exerting force on screw rod output end, please confirm radial force exerted on screw rod output end, under allowable radial force

Type Highlighted quantity of screw rod (mm)	Allowable radial force Fr2							Unit (N)
	JB010	JB025	JB050	JB100	JB200	JB300	JB500	
100	318	570	2500	4010	8210	38200	85300	
200	159	290	1250	2010	4110	23000	50400	
300	106	190	830	1340	2740	15300	33600	
400	79	140	620	1000	2050	11400	25200	
500	64	110	500	800	1640	9100	20200	
600	53	100	420	670	1370	7600	16800	
700	51	90	360	570	1170	6500	14400	
800	48	90	310	500	1030	5700	12600	
900	45	90	280	450	910	5000	11200	
1000	42	90	250	400	820	4500	10100	

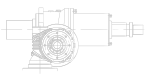

If external diameter force exceeds allowable radial force of screw rod, please add guide device, For example:

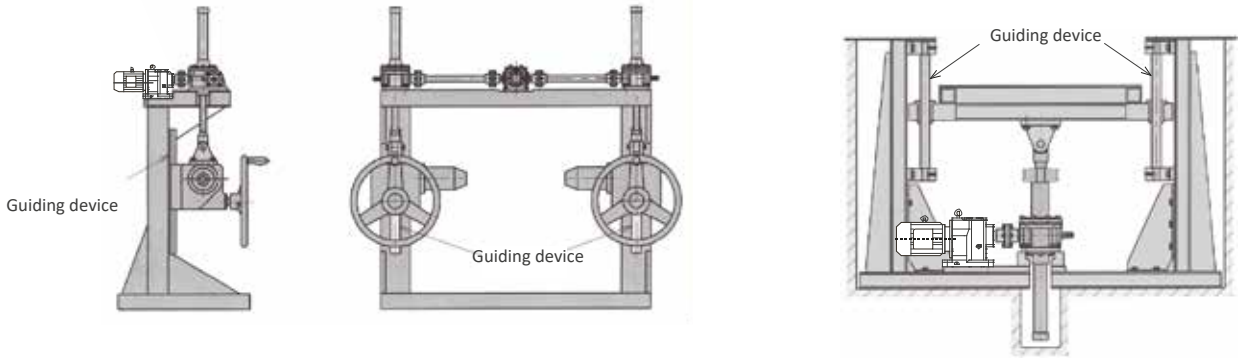

JB

5.8 When elevator transmission is in series (that means the same axial line is equipped with two or more elevators)

Make strenght examination to input shaft end of each elevator:

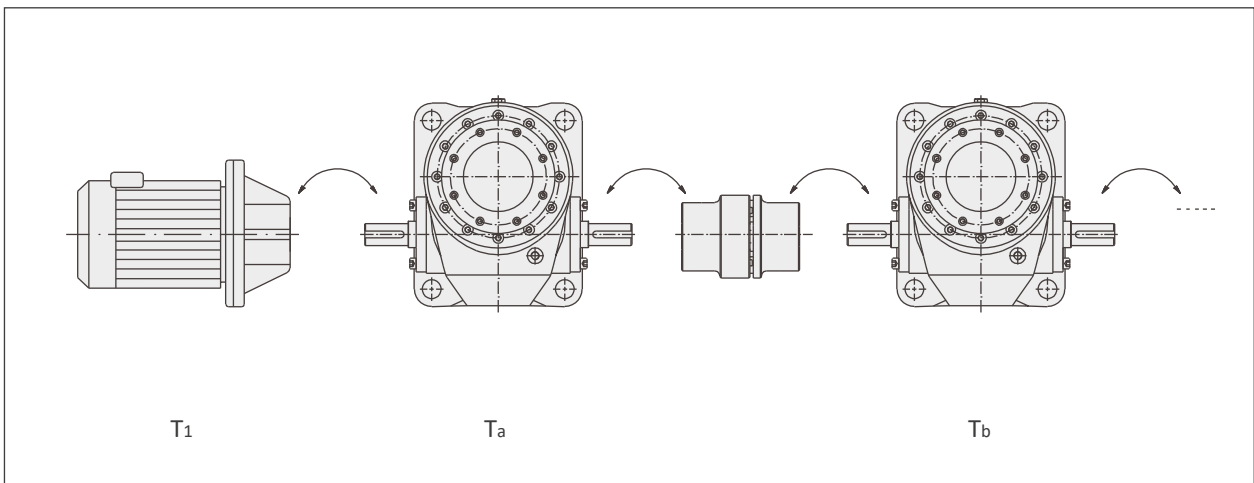

Ta: Input torque needed by elevator a

Tb: Input torque needed by elevator b

Torque needed by motor $T_1 = T_a + T_b < \text{Allowable input shaft torque of elevator a}$

6 Examples:

JB

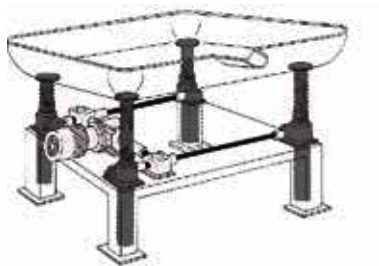

Lifting platform

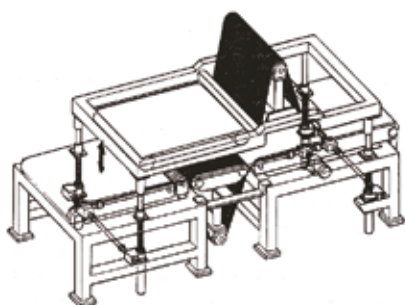
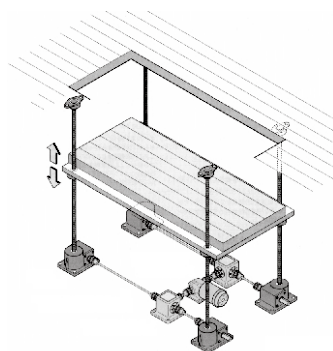

Height adjustment of surface machining tool

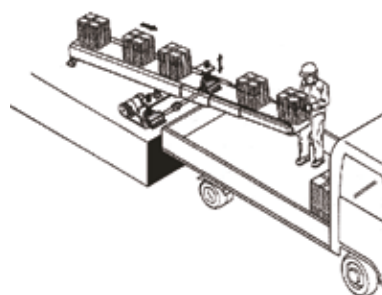

Inclination adjustment of the sliding belt

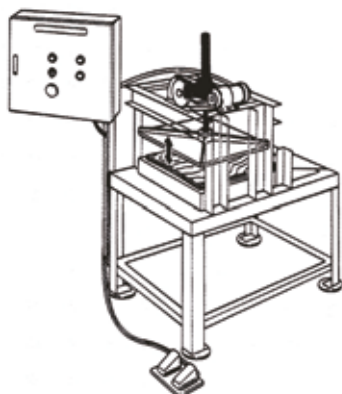

Height adjustment of straightening machine

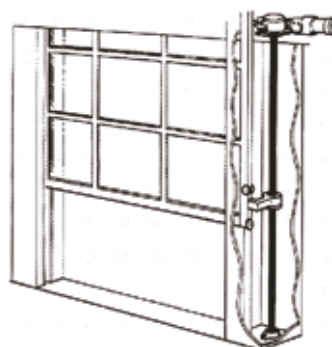

Auto opening of large windows or doors

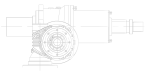

7 Arrangement Type Examples:

7.1 Two sets interlock

Linear



Layout T

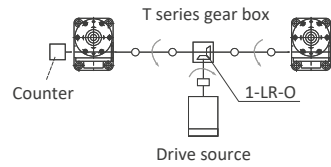

7.2 Four sets interlock

Layout T

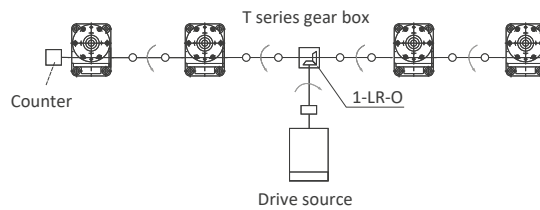

Layout U

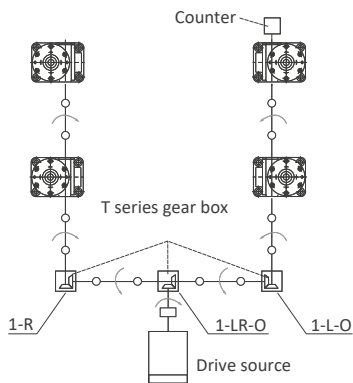

Layout H

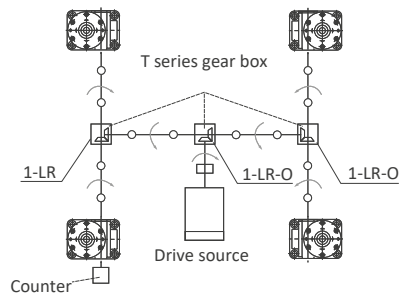

7.3 Eight sets interlock

Layout H

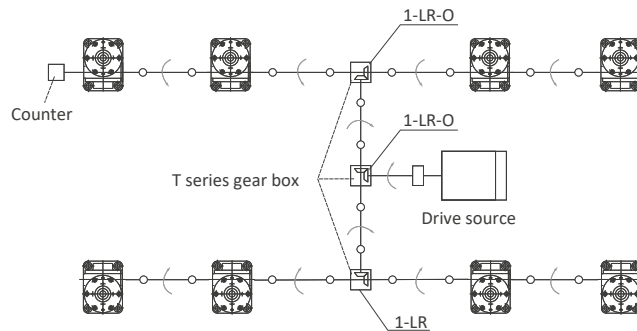

Layout 2H

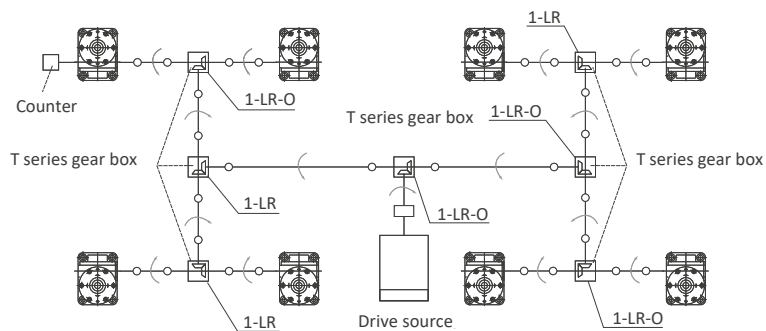

8 Examples Of Type Selection:

Known Criteria:

1. The axial load of the lifting platform: 88KN, lifting speed: 1200mm/min, stroke: 260mm
2. Normal motor: 4 pole, speed $n_1=1450r/min$
3. Load characteristic: moderate, operating 16h/d, starts per hour:10
4. Mounting mode: 4 jacks, Layout H(See 14), foot-mounted with fixed shaft end, accessories with dust-proof cover and output flange.
5. Lateral load, guiding device on one side of the jack.

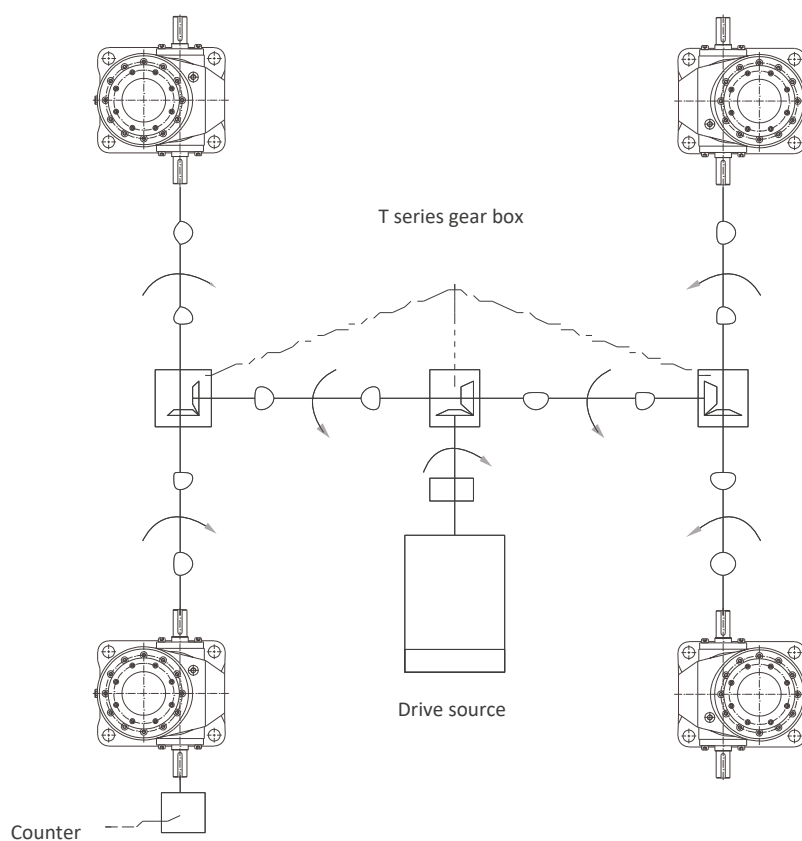

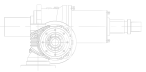

Selection steps:

1. Calculation of total equivalent load W_s (driven machine factor $f_1=1.3$)

$$W_s = W_{max} \cdot f_1 = 88000 \times 1.3 = 114400N$$

2. Calculation of equivalent load of single jack

$$W(\text{arrangement factor } f_d=0.85)$$

$$W = 114400 / (4 \times 0.85) = 33647N$$

3. Initial selection of jack type:

JB050BUA-HD30-D17N7-S selected after considering speed, efficiency, drive source, load and stroke allowance (In reference to the table of technical data, permissible load and distance between action points. If H/L ratio is difficult to determine, use H ratio temporarily)

4. Verification of input power of single jack:

(1) Input power required by single jack:

$$\textcircled{1} n = \frac{v_1}{L_1} \times i = \frac{1.2}{0.01} \times 5.2 = 624 \text{ r/min}$$

$$\textcircled{2} T = \frac{W \times L_1}{2\pi \times i \times \eta} + T_0 = \frac{33647 \times 0.01}{2 \times 3.14 \times 5.2 \times 0.64} + 1.37 = 17.46N \cdot m$$

$$\textcircled{3} P = \frac{T \times n}{9550} = \frac{17.46 \times 624}{9550} = 1.14kW$$

(2) According to the table of technical data,

$$P_{max} = 2.05kW > P \text{ is OK.}$$

5. Verification of screw stability:

According to the table of technical data (page 03) , associated diagram of allowed loading of point distance (page 05~06) and dimension diagram (page 23~24).

$$d=32.4, L_a=(604+33)=637, f_m=20 \times 10^4, S_f=4$$

$$P_{CR} = f_m \times \left(\frac{d}{L_a}\right)^2 = 20 \times 10^4 \times \left(\frac{32.4}{637}\right)^2 = 473073N$$

$$P_{CR} = 473073N > W \times S_f = 33647 \times 4 = 134456N, \dots \text{OK.}$$

6. Verification of critical speed:

Because of none travelling nut type and low rotary speed, the verification of critical speed can be ignored.

7. Drive source options

(1) Required torque per jack:

$$T_{1\sim4} = \frac{T}{\text{Gearbox efficiency}^{\text{No. of gearbox}}} = \frac{17.46}{0.9^2} = 21.56 \text{ N.m}$$

(2) Required torque for the drive unit:

$$T_t = T_1 + T_2 + T_3 + T_4 = 86.24N.m$$

(3) required drive unit capacity:

$$P_t = \frac{T_t \times n}{9550} = \frac{86.64 \times 624}{9550} = 5.63Kw$$

(4) Drive source = required drive unit capacity \times drive unit factor

$$= 5.63 \times 1.3 = 7.32KW$$

Based on above data, we select 7.5KW motor.

! Note: If the above verifications fail, select the larger size jack. For selection of T series gear units, refer to T series brochures.

9 Notes:

- ◆ None of static, dynamic or shock loads should exceed the max permissible load. Selection of a jack with sufficient capacity must be based on safety factor, stroke and screw stability.
- ◆ Make sure that the speed matches the load. Verify the max permissible load, external permissible load and permitted rotary speed of the screw. In case these figures exceed those of the product, severe damage may occur in the machine. The surface temperature of the reduction part and the travelling nut should be within -15~80°C.
- ◆ Permissible speed of the input shaft is 1500r/min. Higher speed are not allowed.
- ◆ JB screw jacks are not designed for continuous duty circle.
- ◆ The unit of %ED for single screw jack is 30min JB (Ball screw screw) duty circle must be less than 30%ED

$$ED = \frac{\text{work time in one load circle}}{\text{work time in one load circle} + \text{rest time in one load circle}} \times 100\%$$

- ◆ If several screw jacks are arranged in an axial line, verify the strength of the input shaft and make sure the torque of each jack stay within the permissible input torque.
- ◆ Make sure the starting torque of the drive source is greater than 200% of the service torque.
- ◆ When working under below 0°C, the screw jack must be guaranteed by sufficient drive source, for its efficiency decreases as a result of the viscosity change in the grease.
- ◆ JB Ball screw Jack does not have a self-locking device, therefore, a brake mechanism is required.
- ◆ The normal ambient environment: ambient temperature -10 to 40°C, ample space, good ventilation, altitude not exceeding 1000m and normal plant dust.
- ◆ When working in places with volume of dust, bellows should be supplied to guard the screw. In the open air, use the covers to protect the machine against rains and sunlight.
- ◆ Do not halt the screw jack intentionally during its operation, for it may cause severe damage to the product. Since JB Ball screw Jack is highly efficient, sufficient brake that over powers the "holding torque" is required to sustain its shaft.

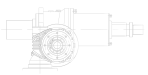

10 Outline Dimension:

JB010

JB

Stroke (mm)	BU					
	X		X ⁽¹⁾		L	m(kg)
	MIN	MAX	MIN	MAX		
100	162	262	212	312	194	6.7
200	162	362	212	412	294	7
300	162	462	252	552	434	7.4
400	162	562	252	652	534	7.6
500	162	662	287	787	669	8
600	162	762	287	887	769	8.2
800	162	962	322	1122	1004	8.7
1000	162	1162	352	1352	1234	9.2

Stroke (mm)	BD					
	X		X ⁽¹⁾		L	m(kg)
	MIN	MAX	MIN	MAX		
100	25	125	75	175	194	6.7
200	25	225	75	275	294	7
300	25	325	115	415	434	7.4
400	25	425	115	515	534	7.6
500	25	525	150	650	669	8
600	25	625	150	750	769	8.2
800	25	825	185	985	1004	8.7
1000	25	1025	215	1215	1234	9.2

Stroke (mm)	RU					
	X		X ⁽¹⁾		L	m(kg)
	MIN	MAX	MIN	MAX		
100	162	262	212	312	194	7.5
200	162	362	212	412	294	8.2
300	162	462	252	552	434	9.1
400	162	562	252	652	534	9.8
500	162	662	287	787	669	11
600	162	762	287	887	769	12
800	162	962	322	1122	1004	13.5
1000	162	1162	352	1352	1234	15

Stroke (mm)	RD					
	X		X ⁽¹⁾		L	m(kg)
	MIN	MAX	MIN	MAX		
100	25	125	75	175	194	7.5
200	25	225	75	275	294	8.2
300	25	325	115	415	434	9.1
400	25	425	115	515	534	9.8
500	25	525	150	650	669	11
600	25	625	150	750	769	12
800	25	825	185	985	1004	13.5
1000	25	1025	215	1215	1234	15

X Direction

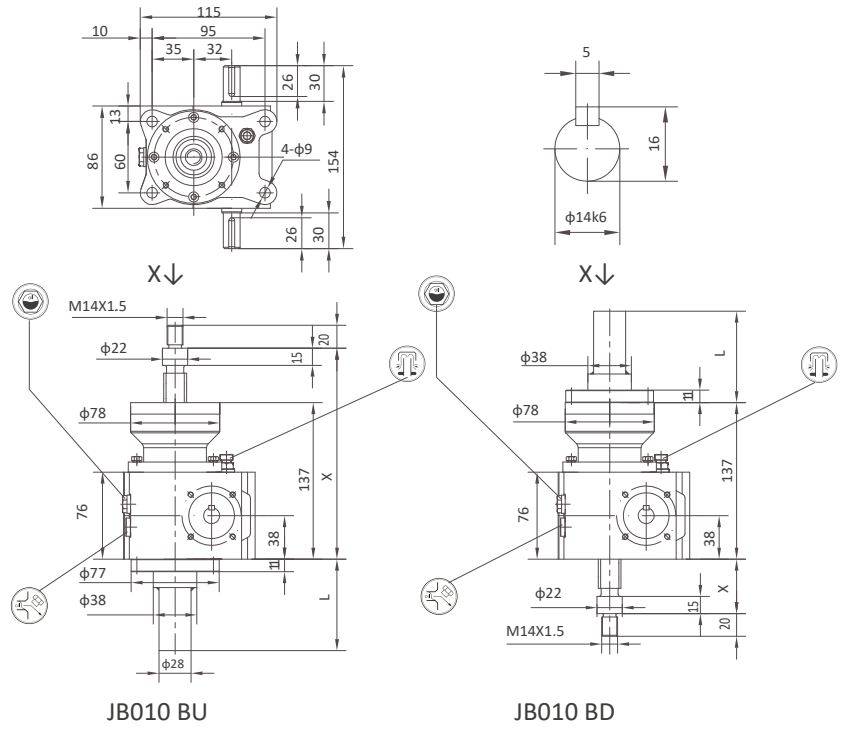

JB010 BU

JB010 BD

X Direction

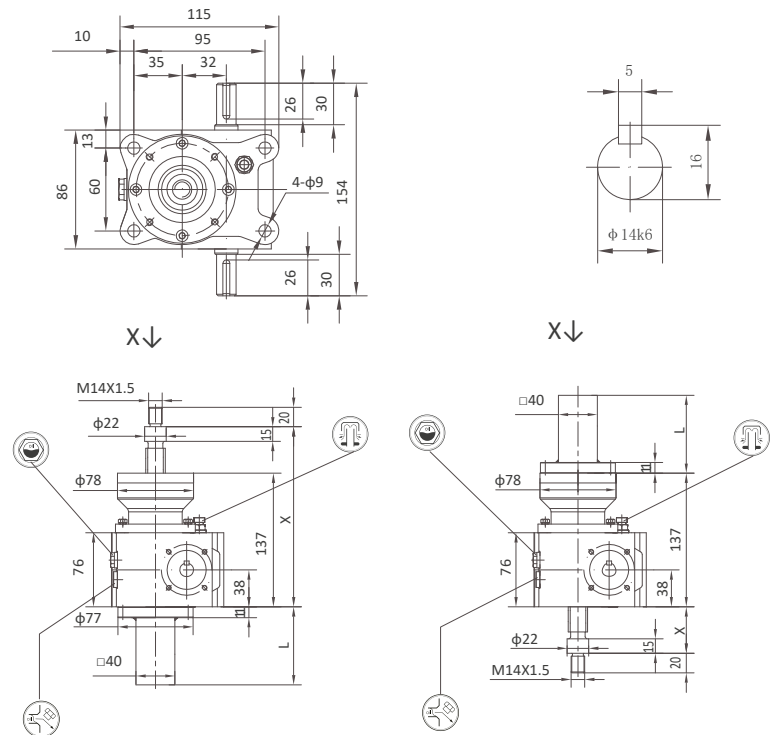

JB010 RU

JB010 RD

Note: X⁽¹⁾ dimension with dust-proof cover.

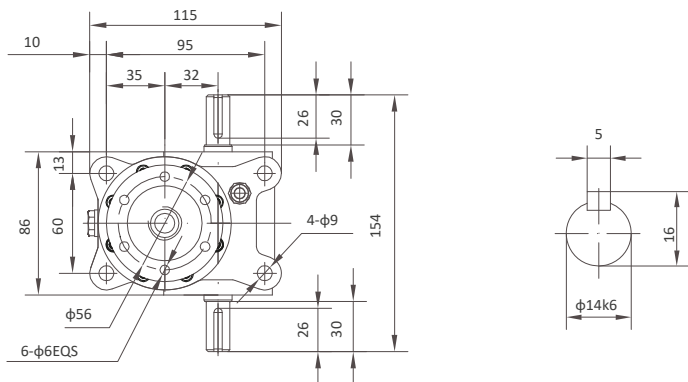
X Direction

Stroke (mm)	NU			m(kg)
	X		Y	
	MIN	MAX		
100	107	207	268	5.9
200	107	307	368	6.1
300	107	407	468	6.4
400	107	507	568	6.6
500	107	607	668	6.8
600	107	707	768	7
800	107	907	968	7.4
1000	107	1107	1168	7.8

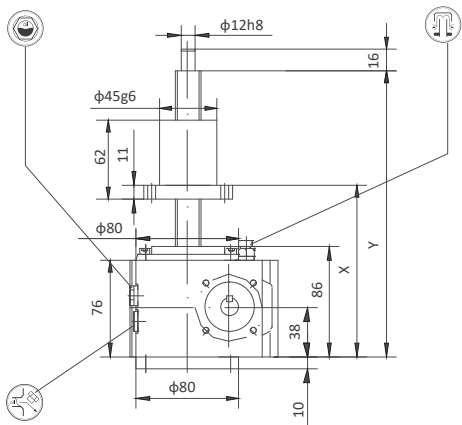
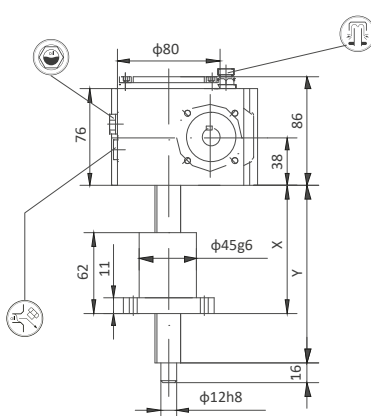
X ↓

JB010 NU
X ↓

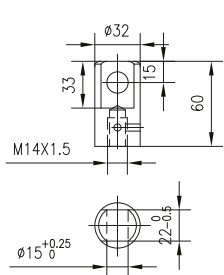
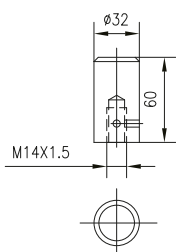
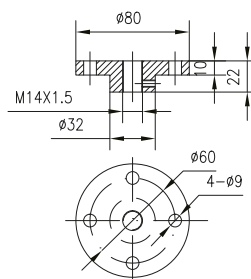
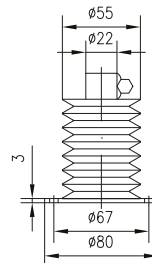
JB010 ND

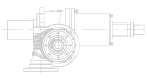
Stroke (mm)	ND			m(kg)
	X		Y	
	MIN	MAX		
100	82	182	192	5.9
200	82	282	292	6.1
300	82	382	392	6.4
400	82	482	492	6.6
500	82	582	592	6.8
600	82	682	692	7
800	82	882	892	7.4
1000	82	1082	1092	7.8



I type connection

B type connection

Output flange

Dust-proof cover

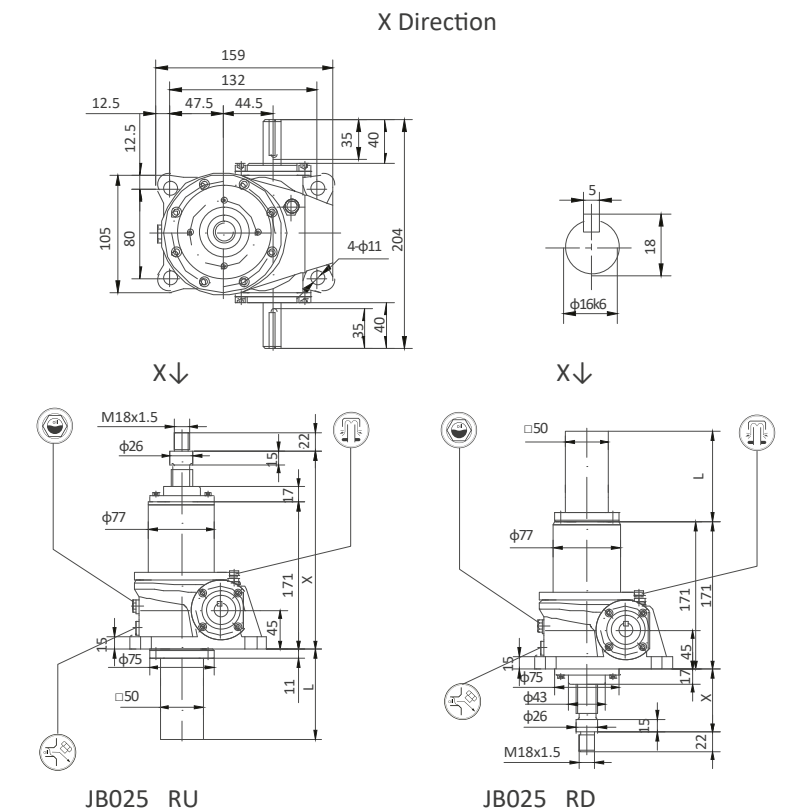
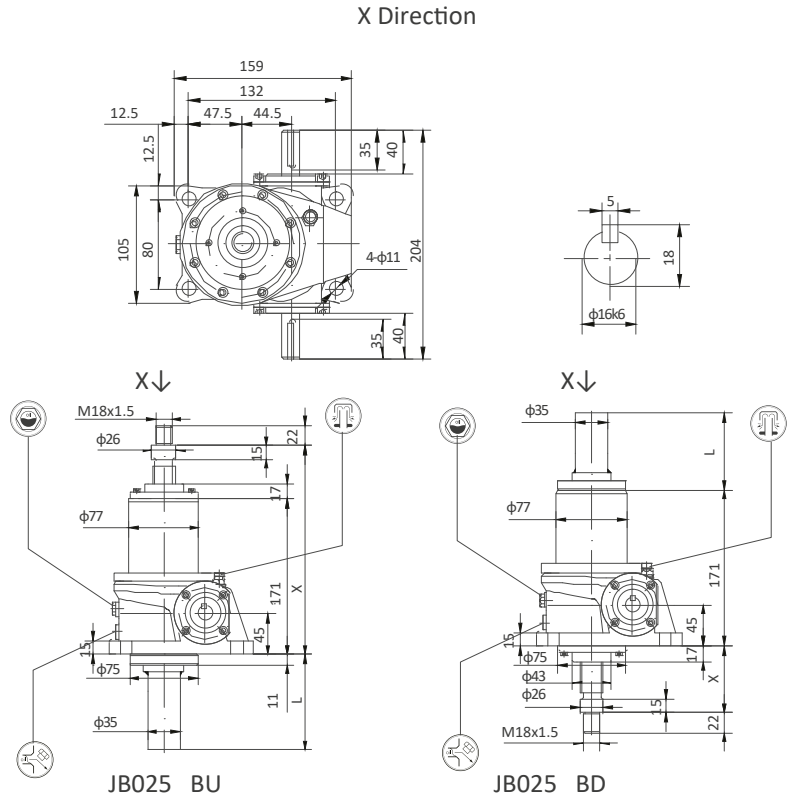

10 Outline Dimension:

JB025

Stroke (mm)	BU					
	X		X ⁽¹⁾		L	m(kg)
	MIN	MAX	MIN	MAX		
100	213	313	228	328	149	11
200	213	413	228	428	249	11.3
300	213	513	248	548	369	11.6
400	213	613	248	648	469	12
500	213	713	268	768	589	12.5
600	213	813	268	868	689	13
800	213	1013	288	1088	909	14
1000	213	1213	308	1308	1129	15
1200	213	1413	323	1523	1344	16
Stroke (mm)	BD					
	X		X ⁽¹⁾		L	m(kg)
	MIN	MAX	MIN	MAX		
100	42	142	57	157	149	11
200	42	242	57	257	249	11.3
300	42	342	77	377	369	11.6
400	42	442	77	477	469	12
500	42	542	97	597	589	12.5
600	42	642	97	697	689	13
800	42	842	117	917	909	14
1000	42	1042	137	1137	1129	15
1200	42	1242	152	1352	1344	16
Stroke (mm)	RU					
	X		X ⁽¹⁾		L	m(kg)
	MIN	MAX	MIN	MAX		
100	213	313	228	328	175	12
200	213	413	228	428	275	13
300	213	513	248	548	395	15
400	213	613	248	648	495	16
500	213	713	268	768	615	17
600	213	813	268	868	715	18
800	213	1013	288	1088	935	21
1000	213	1213	308	1308	1155	24
1200	213	1413	323	1523	1370	27
Stroke (mm)	RD					
	X		X ⁽¹⁾		L	m(kg)
	MIN	MAX	MIN	MAX		
100	42	142	57	157	175	12
200	42	242	57	257	275	13
300	42	342	77	377	395	15
400	42	442	77	477	495	16
500	42	542	97	597	615	17
600	42	642	97	697	715	18
800	42	842	117	917	935	21
1000	42	1042	137	1137	1155	24
1200	42	1242	152	1352	1370	27

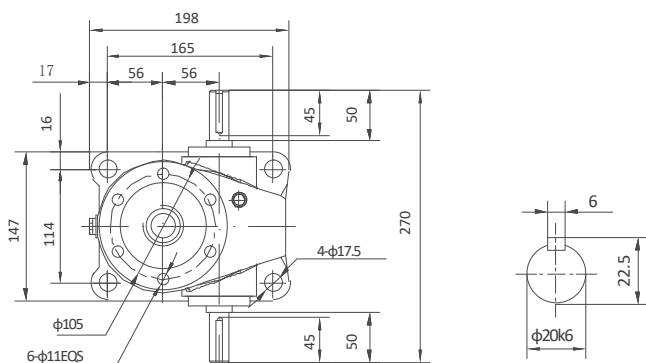
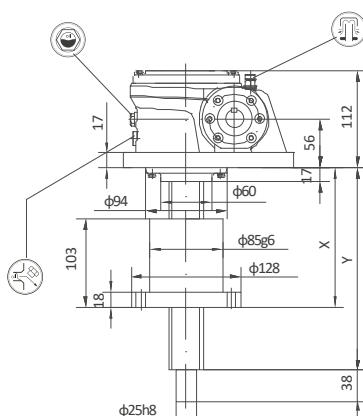
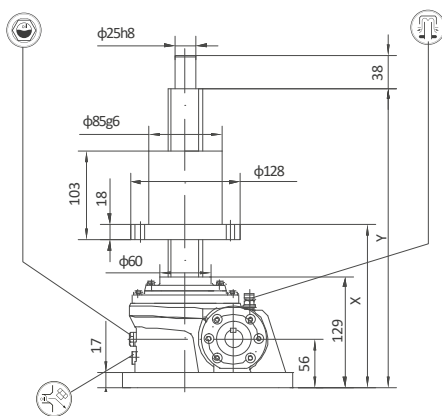

▲ Note: X⁽¹⁾ dimension with dust-proof cover.

X Direction

X↓
X↓

JB050 NU
JB050 ND

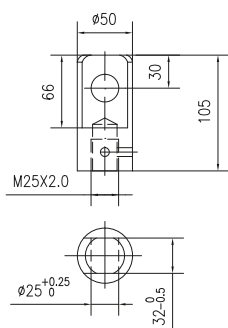
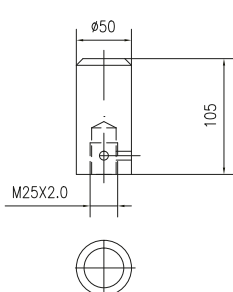
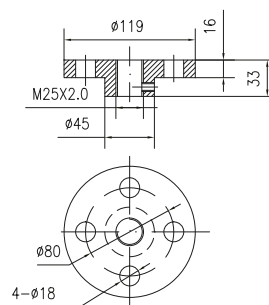
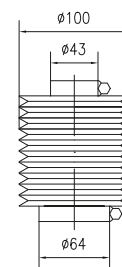
Stroke (mm)	NU			
	X		Y	m(kg)
	MIN	MAX		
100	157	257	352	31
200	157	357	452	32
300	157	457	552	33
400	157	557	652	34
500	157	657	752	35
600	157	757	852	36
800	157	957	1052	39
1000	157	1157	1252	41
1200	157	1357	1452	43
1500	157	1657	1752	46

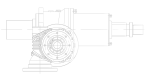
Stroke (mm)	ND			
	X		Y	m(kg)
	MIN	MAX		
100	130	230	240	31
200	130	330	340	32
300	130	430	440	33
400	130	530	540	34
500	130	630	640	35
600	130	730	740	36
800	130	930	940	39
1000	130	1130	1140	41
1200	130	1330	1340	43
1500	130	1630	1640	46

I type connection

B type connection

Output flange

Dust-proof cover



10 Outline Dimension:

JB100

Stroke (mm)	BU					
	X		X ⁽¹⁾		L	m(kg)
	MIN	MAX	MIN	MAX		
100	302	402	312	412	151	36
200	302	502	312	512	252	38
300	302	602	327	627	366	41
400	302	702	327	727	466	43
500	302	802	352	852	591	46
600	302	902	352	952	691	48
800	302	1102	367	1167	906	53
1000	302	1302	377	1377	1116	58
1200	302	1502	402	1602	1341	63
1500	302	1802	427	1927	1666	71

Stroke (mm)	BD					
	X		X ⁽¹⁾		L	m(kg)
	MIN	MAX	MIN	MAX		
100	42	142	52	152	151	36
200	42	242	52	252	252	38
300	42	342	67	367	366	41
400	42	442	67	467	466	43
500	42	542	92	592	591	46
600	42	642	92	692	691	48
800	42	842	107	907	906	53
1000	42	1042	117	1117	1116	58
1200	42	1242	142	1342	1341	63
1500	42	1542	167	1667	1666	71

Stroke (mm)	RU					
	X		X ⁽¹⁾		L	m(kg)
	MIN	MAX	MIN	MAX		
100	302	402	312	412	180	39
200	302	502	312	512	282	42
300	302	602	327	627	396	45
400	302	702	327	727	496	48
500	302	802	352	852	621	52
600	302	902	352	952	721	55
800	302	1102	367	1167	936	61
1000	302	1302	377	1377	1146	67
1200	302	1502	402	1602	1371	74
1500	302	1802	427	1927	1707	84

Stroke (mm)	RD					
	X		X ⁽¹⁾		L	m(kg)
	MIN	MAX	MIN	MAX		
100	42	142	52	152	180	39
200	42	242	52	252	282	42
300	42	342	67	367	396	45
400	42	442	67	467	496	48
500	42	542	92	592	621	52
600	42	642	92	692	721	55
800	42	842	107	907	936	61
1000	42	1042	117	1117	1146	67
1200	42	1242	142	1342	1371	74
1500	42	1542	167	1667	1707	84

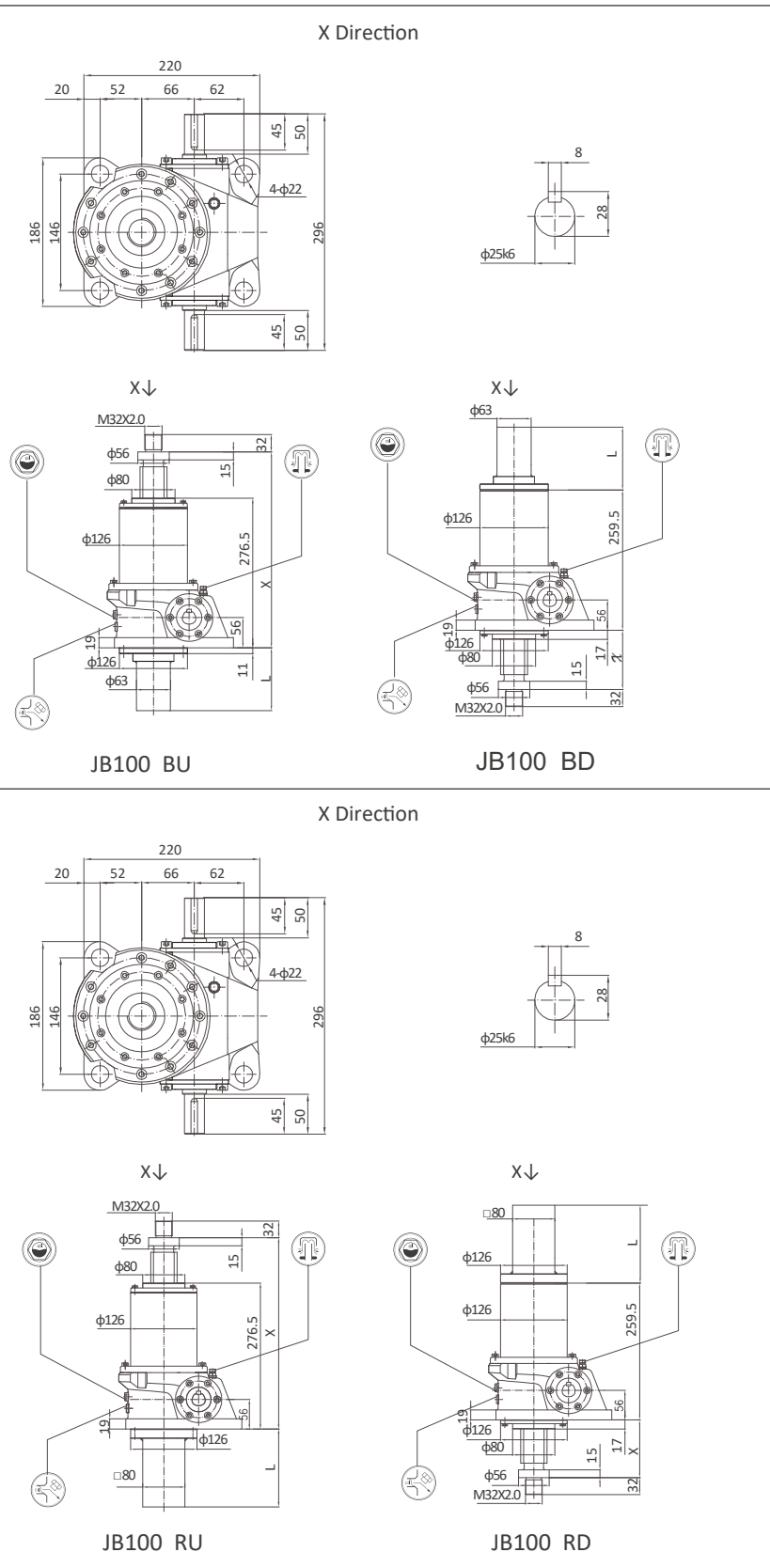

⚠ Note: X⁽¹⁾ dimension with dust-proof cover.

X Direction

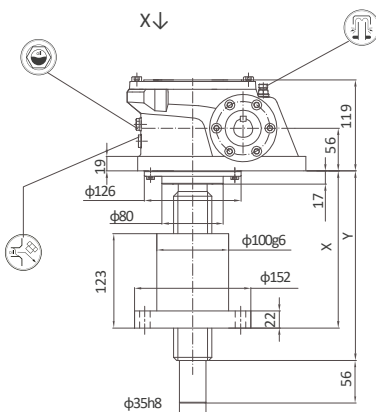
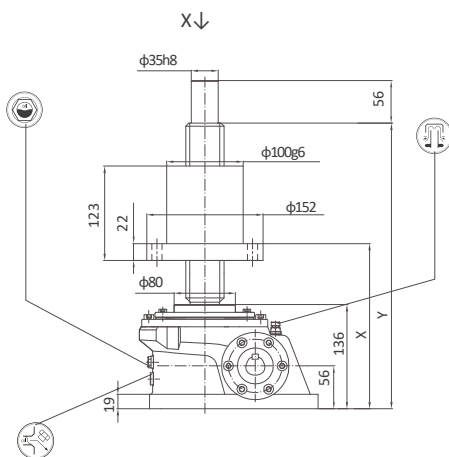
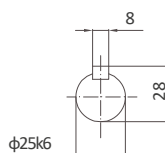
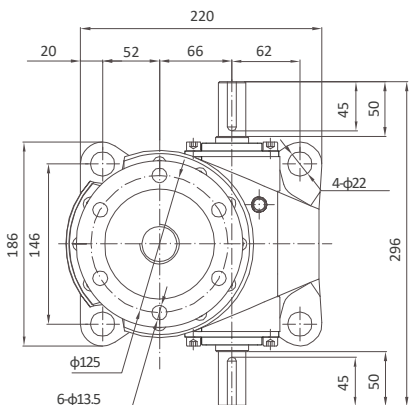

JB100 NU

JB100 ND

Stroke (mm)	NU			
	X		Y	m(kg)
	MIN	MAX		
100	169	269	380	31
200	169	369	480	32
300	169	469	580	33
400	169	569	680	34
500	169	669	780	35
600	169	769	880	36
800	169	969	1080	39
1000	169	1169	1280	41
1200	169	1369	1480	43
1500	169	1669	1780	45

Stroke (mm)	ND			
	X		Y	m(kg)
	MIN	MAX		
100	158	258	268	31
200	158	358	368	32
300	158	458	468	33
400	158	558	568	34
500	158	658	668	35
600	158	758	768	36
800	158	958	968	39
1000	158	1158	1168	41
1200	158	1358	1368	43
1500	158	1658	1668	45

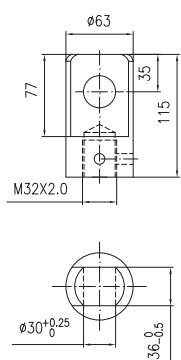

I type connection

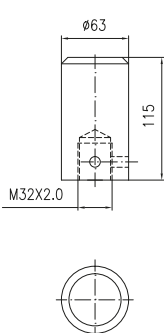

B type connection

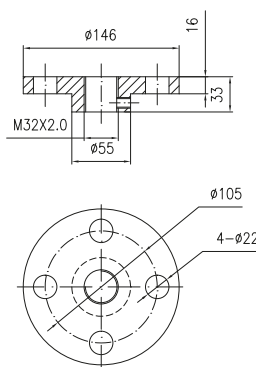

Output flange

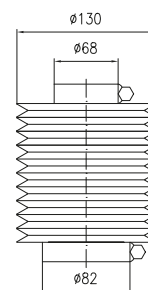

Dust-proof cover

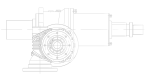

10 Outline Dimension:

JB200

Stroke (mm)	BU					L	m(kg)
	X		X ⁽¹⁾				
	MIN	MAX	MIN	MAX			
100	366	466	376	476	151	65	
200	366	566	376	576	252	68	
300	366	666	391	691	366	72	
400	366	766	391	791	466	76	
500	366	866	416	916	591	80	
600	366	966	416	1016	691	83	
800	366	1166	431	1231	906	90	
1000	366	1366	441	1441	1116	97	
1200	366	1566	466	1666	1341	105	
1500	366	1866	491	1991	1666	118	
2000	366	2366	536	2536	2211	141	

Stroke (mm)	BD					L	m(kg)
	X		X ⁽¹⁾				
	MIN	MAX	MIN	MAX			
100	42	142	52	152	151	65	
200	42	242	52	252	252	68	
300	42	342	67	367	366	72	
400	42	442	67	467	466	76	
500	42	542	92	592	591	80	
600	42	642	92	692	691	83	
800	42	842	107	907	906	90	
1000	42	1042	117	1117	1116	97	
1200	42	1242	142	1342	1341	105	
1500	42	1542	167	1667	1666	118	
2000	42	2042	212	2212	2211	141	

Stroke (mm)	RU					L	m(kg)
	X		X ⁽¹⁾				
	MIN	MAX	MIN	MAX			
100	366	466	376	476	170	72	
200	366	566	376	576	270	76	
300	366	666	391	691	385	80	
400	366	766	391	791	486	84	
500	366	866	416	916	610	89	
600	366	966	416	1016	710	93	
800	366	1166	431	1231	925	102	
1000	366	1366	441	1441	1135	110	
1200	366	1566	466	1666	1360	119	
1500	366	1866	491	1991	1686	133	
2000	366	2366	536	2536	2231	158	

Stroke (mm)	RD					L	m(kg)
	X		X ⁽¹⁾				
	MIN	MAX	MIN	MAX			
100	42	142	52	152	170	72	
200	42	242	52	252	270	76	
300	42	342	67	367	385	80	
400	42	442	67	467	486	84	
500	42	542	92	592	610	89	
600	42	642	92	692	710	93	
800	42	842	107	907	925	102	
1000	42	1042	117	1117	1135	110	
1200	42	1242	142	1342	1360	119	
1500	42	1542	167	1667	1686	133	
2000	42	2042	212	2212	2231	158	

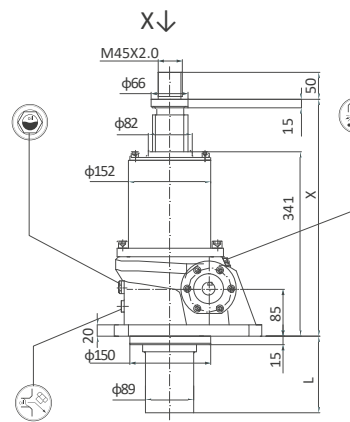
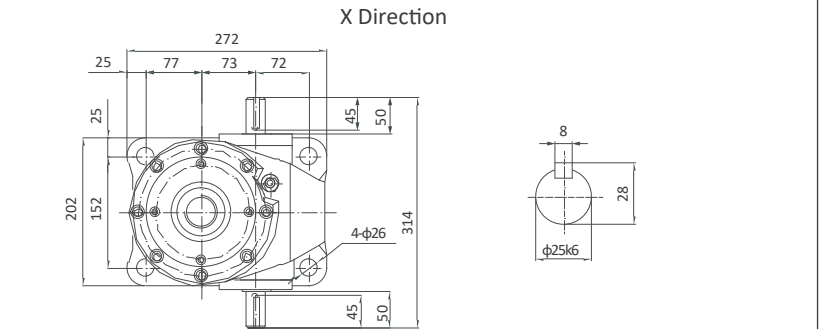

JB200 BU

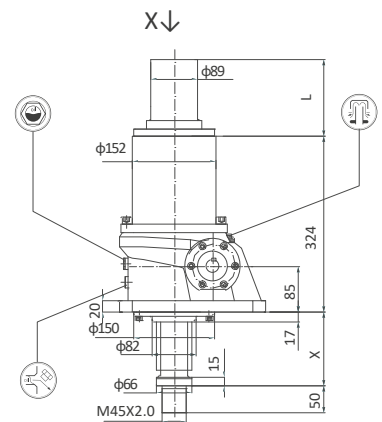

JB200 BD

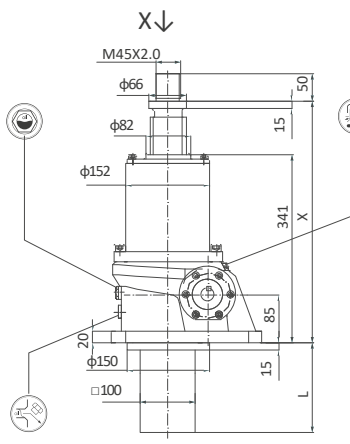
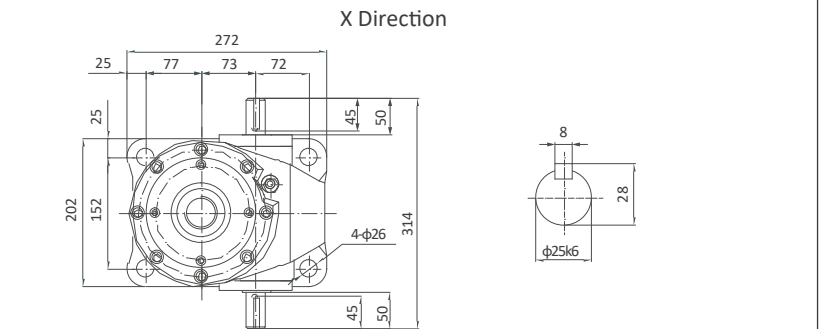

JB200 RU

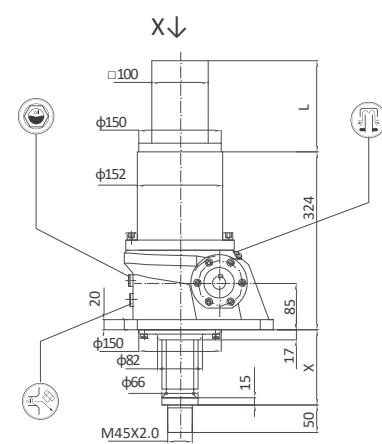

JB200 RD

▲ Note: X⁽¹⁾ dimension with dust-proof cover.

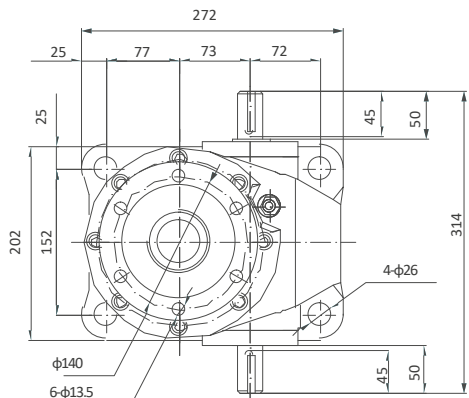
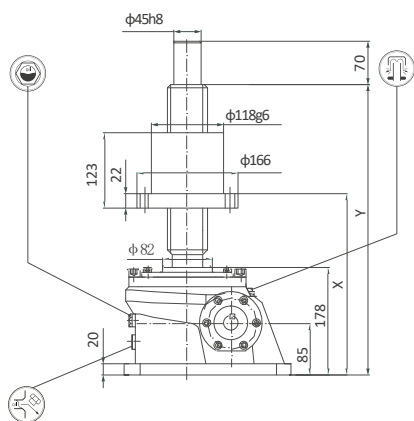
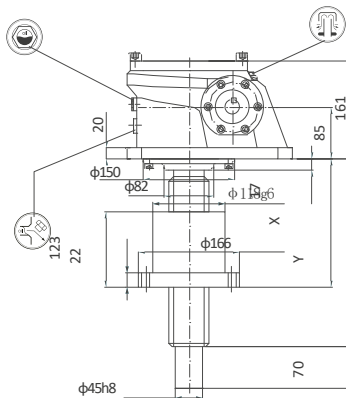
X Direction

X ↓

JB200 NU
X ↓

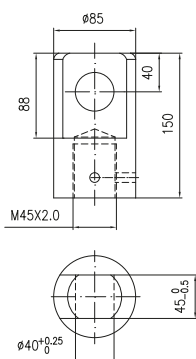
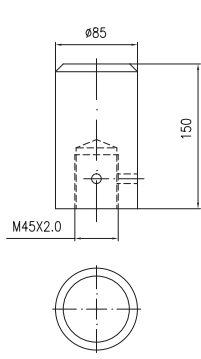
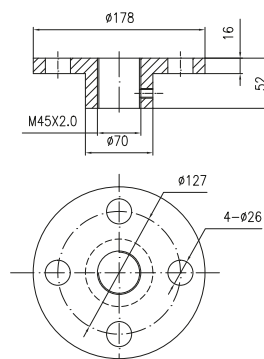
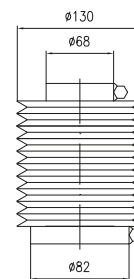
JB200 ND

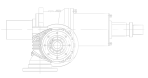
Stroke (mm)	NU			
	X		Y	m(kg)
	MIN	MAX		
100	219	319	430	56
200	219	419	530	58
300	219	519	630	60
400	219	619	730	62
500	219	719	830	65
600	219	819	930	67
800	219	1019	1130	71
1000	219	1219	1330	76
1200	219	1419	1530	80
1500	219	1719	1830	88
2000	219	2219	2330	101

Stroke (mm)	ND			
	X		Y	m(kg)
	MIN	MAX		
100	150	250	260	56
200	150	350	360	58
300	150	450	460	60
400	150	550	560	62
500	150	650	660	65
600	150	750	760	67
800	150	950	960	71
1000	150	1150	1160	76
1200	150	1350	1360	80
1500	150	1650	1660	88
2000	150	2150	2160	101

I type connection

B type connection

Output flange

Dust-proof cover



10 Outline Dimension:

JB300

Stroke (mm)	BU					
	X		X ⁽¹⁾		L	m(kg)
	MIN	MAX	MIN	MAX		
100	435	535	445	545	160	153
200	435	635	445	645	260	159
300	435	735	460	760	375	166
400	435	835	460	860	475	172
500	435	935	475	975	590	178
600	435	1035	475	1075	690	184
800	435	1235	490	1290	905	197
1000	435	1435	510	1510	1125	210
1200	435	1635	520	1720	1335	223
1500	435	1935	545	2045	1660	242
2000	435	2435	580	2580	2195	276

Stroke (mm)	BD					
	X		X ⁽¹⁾		L	m(kg)
	MIN	MAX	MIN	MAX		
100	55	155	65	165	160	153
200	55	255	65	265	260	159
300	55	355	80	380	375	166
400	55	455	80	480	475	172
500	55	555	95	595	590	178
600	55	655	95	695	690	184
800	55	855	110	910	905	197
1000	55	1055	130	1130	1125	210
1200	55	1255	140	1340	1335	223
1500	55	1555	165	1665	1660	242
2000	55	2055	200	2200	2195	276

JB300 BU
X Direction

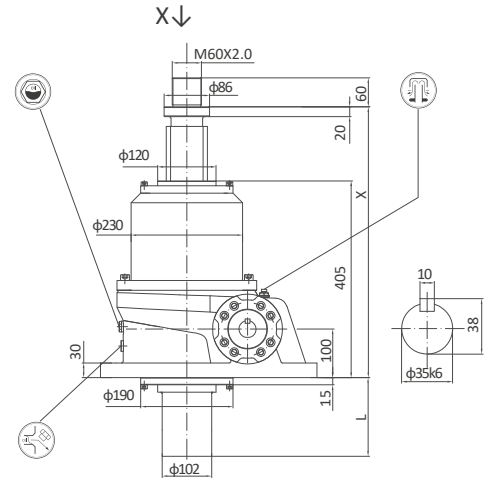
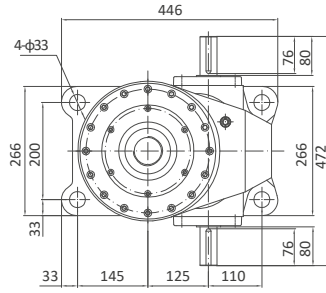

JB300 BD
X Direction

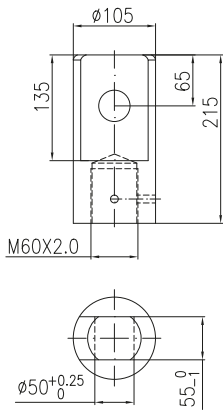
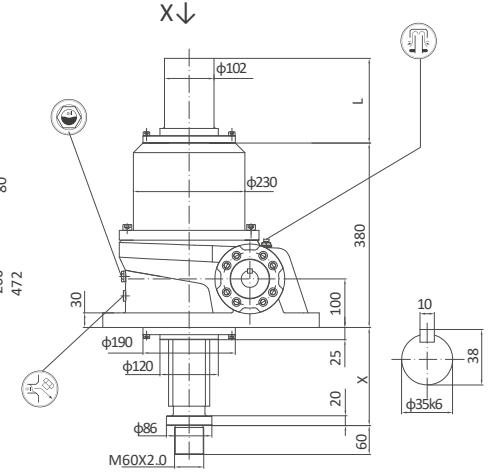
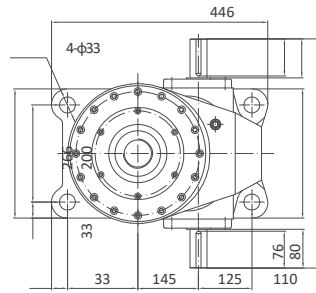

I type connection

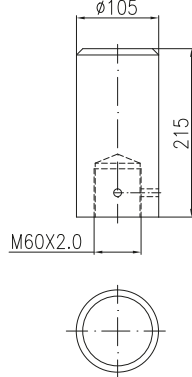

B type connection

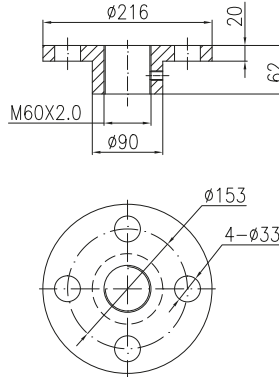

Output flange

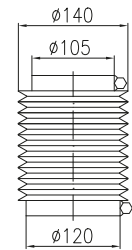

Dust-proof cover

⚠ Note: X⁽¹⁾ dimension with dust-proof cover.

10 Outline Dimension:

JB500

JB

JB500 BU

X Direction

Stroke (mm)	BU					
	X		X ⁽¹⁾		L	m(kg)
	MIN	MAX	MIN	MAX		
100	540	640	545	645	165	310
200	540	740	545	745	265	320
300	540	840	565	865	385	330
400	540	940	565	965	485	340
500	540	1040	575	1075	595	350
600	540	1140	575	1175	695	359
800	540	1340	590	1390	910	378
1000	540	1540	605	1605	1125	398
1200	540	1740	615	1815	1335	417
1500	540	2040	635	2135	1665	446
2000	540	2540	670	2670	2190	497

JB500 BD

X Direction

Stroke (mm)	BD					
	X		X ⁽¹⁾		L	m(kg)
	MIN	MAX	MIN	MAX		
100	54	154	59	159	165	310
200	54	254	59	259	265	320
300	54	354	79	379	385	330
400	54	454	79	479	485	340
500	54	554	89	589	595	350
600	54	654	89	689	695	359
800	54	854	104	904	910	378
1000	54	1054	119	1119	1125	398
1200	54	1254	129	1329	1335	419
1500	54	1554	149	1649	1665	446
2000	54	2054	184	2184	2190	497

I type connection

B type connection

Output flange

Dust-proof cover

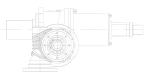

11 Input Modes:

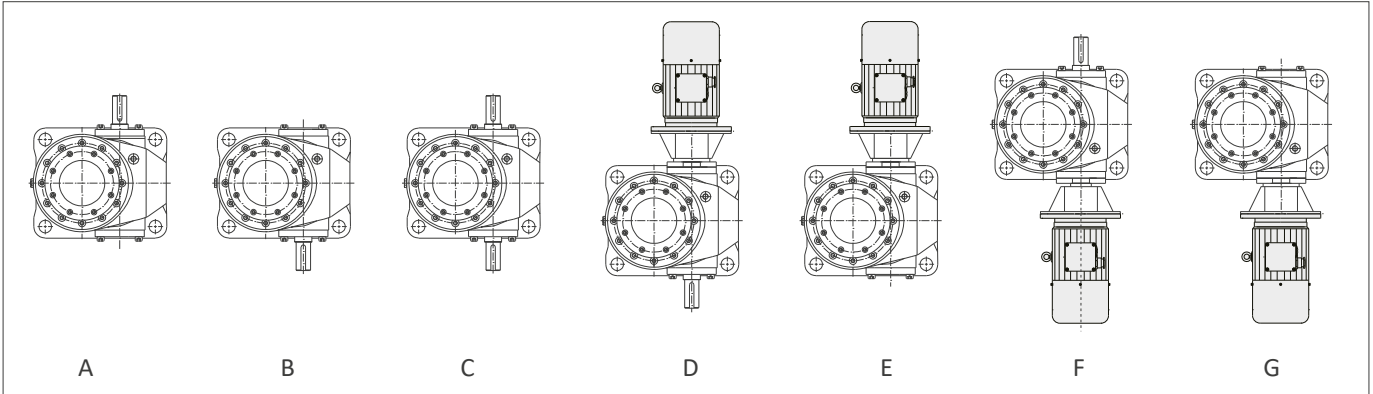

12 Direct-linking Input:

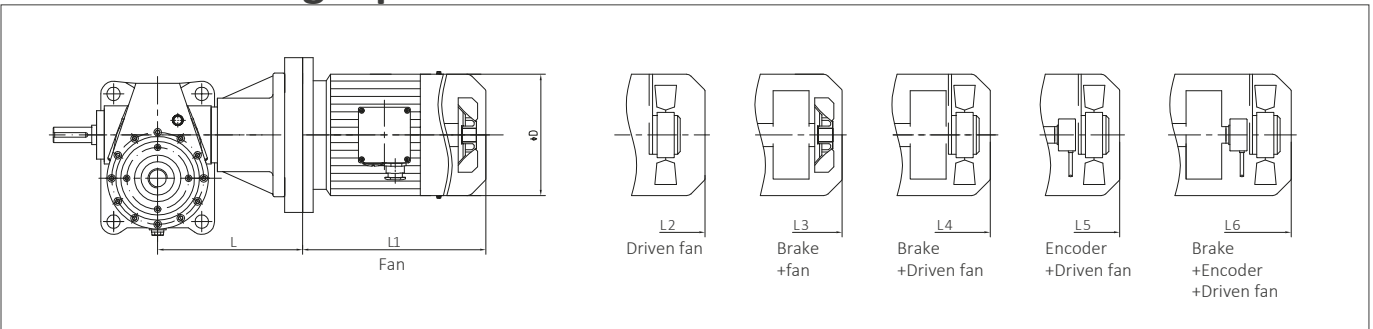

Type	Power(kW)	L1(mm)	L2(mm)	L3(mm)	L4(mm)	L5(mm)	L6(mm)	D(mm)	L(mm)
JB010	0.12	192	247	227	282	/	/	124	118
	0.18	192	247	227	282	/	/	124	118
	0.25	214	259	254	304	304	344	139	120
	0.37	214	259	254	304	304	344	139	120
JB025	0.12	192	247	227	282	/	/	124	145
	0.18	192	247	227	282	/	/	124	145
	0.25	214	259	254	304	304	344	139	145
	0.37	214	259	254	304	304	344	139	145
	0.55	261	306	321	366	366	416	159	145
	0.75	261	306	321	366	366	416	159	145
JB050	0.25	214	259	254	304	304	344	139	187
	0.37	214	259	254	304	304	344	139	187
	0.55	261	306	321	366	366	416	159	187
	0.75	261	306	321	366	366	416	159	187
	1.1	284	329	339	384	384	439	176	187
	1.5	284	329	339	384	384	439	176	187
JB100	0.37	214	259	254	304	304	344	139	220
	0.55	261	306	321	366	366	416	159	223
	0.75	261	306	321	366	366	416	159	223
	1.1	284	329	339	384	384	439	176	223
	1.5	284	329	339	384	384	439	176	223
	2.2	349	389	424	464	464	519	199	230
JB200	0.75	261	306	321	366	366	416	159	241
	1.1	284	329	339	384	384	439	176	241
	1.5	284	329	339	384	384	439	176	241
	2.2	349	389	424	464	464	519	199	248
	3	349	389	424	464	464	519	199	248
	4	412	462	487	537	537	592	220	248

Note:1:Power of motor should be conformed with the transmission capacity.

2:The power is for 4-pole motor

13 Combined-type

13.1 Dimensions of combined-type

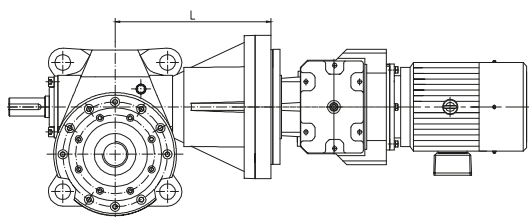

JR/CR Combined type

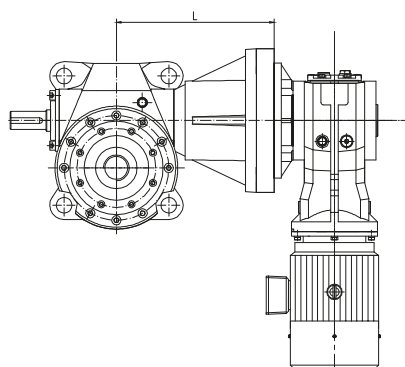

JR/K Combined type

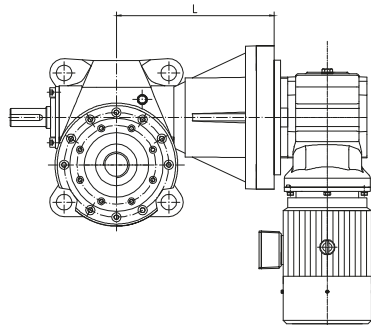

JR/S Combined type

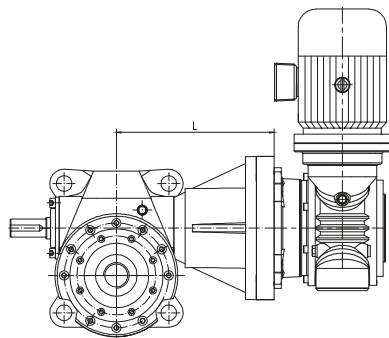

JR/R Combined type

Type	L
JB025../C.01..	145
JB025../R050..	145
JB050../CRL37..	187
JB050../KF37..	187
JB050../S203..	187
JB050../R063..	187
JB100../CRL37..	220
JB100../KF37..	220
JB100../S203..	220
JB100../CR47..	220
JB100../KF47..	223
JB100../S204..	223
JB100../R063..	220
JB100../R080..	223
JB200../CRL37..	238
JB200../KF37..	238
JB200../S203..	238
JB200../CRL47..	244
JB200../KF47..	241
JB200../S204..	241
JB200../CRL67..	248
JB200../KF67..	248
JB200../S206..	248
JB200../R080..	241
JB200../R100..	248

JB

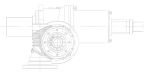

13.2 Arrangement of combined type

JB

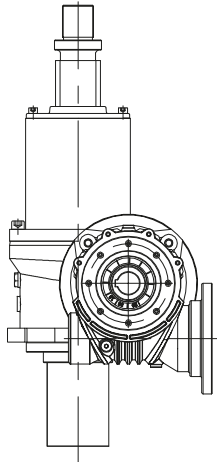

ZR01

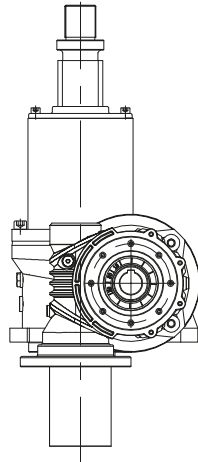

ZR02

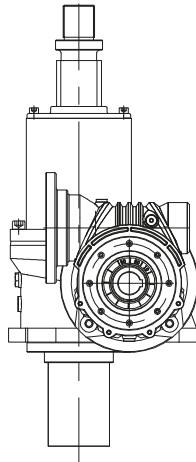

ZR03

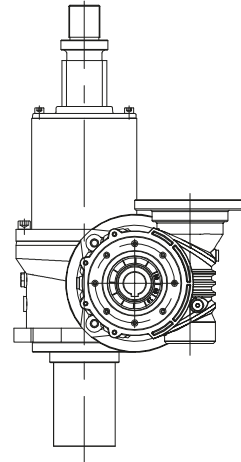

ZR04

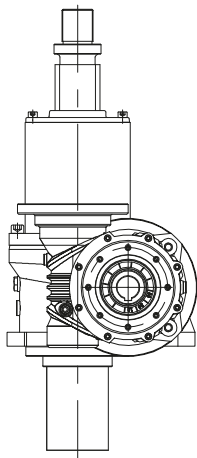

ZR05

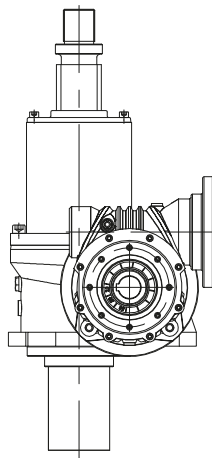

ZR06

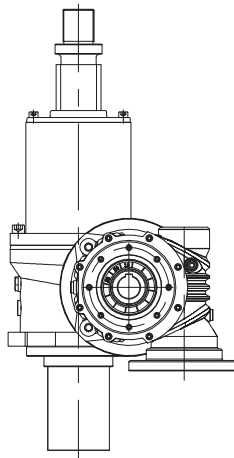

ZR07

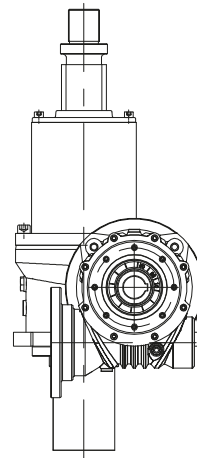

ZR08

14 Attachment: 14.1 Base

Bases are widely used in switching and inclining devices.

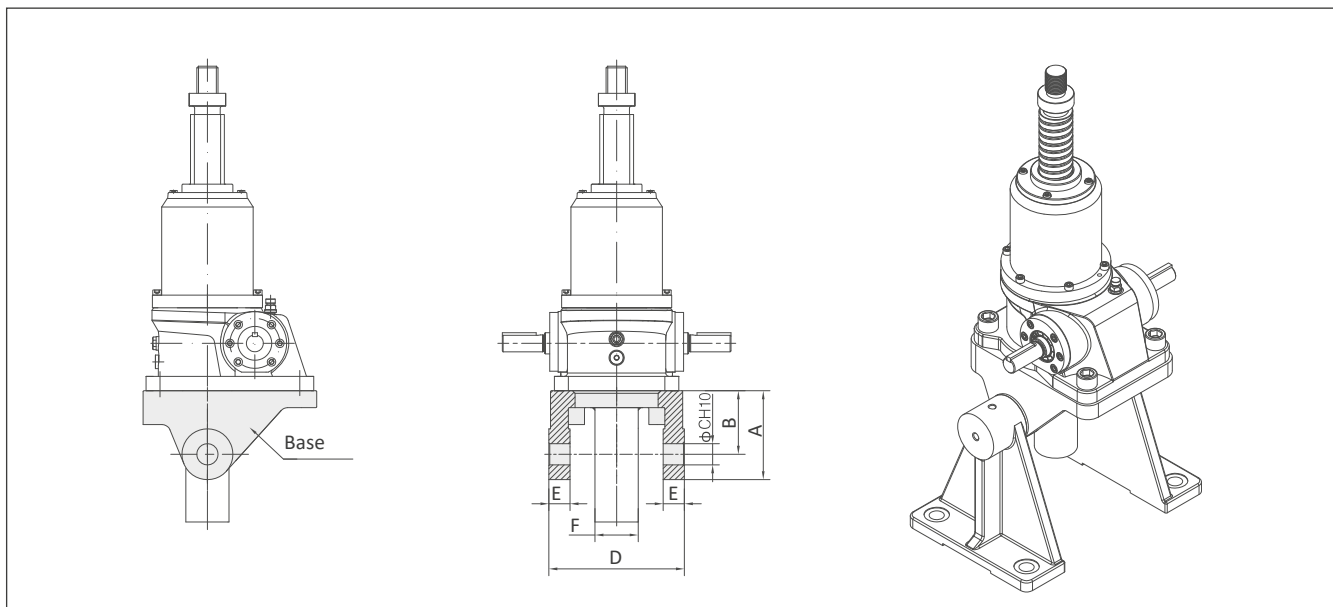

JB

Type	A	B	C	D	E	F
JB010	75	60	15	86	15	40
JB025	100	75	20	115	20	50
JB050	105	75	25	158	25	60
JB100	145	100	40	201	30	80
JB200	173	110	63	244	50	100

14.2 Support legs

Bases and support legs are often used together to make lifting function in multiple directions.

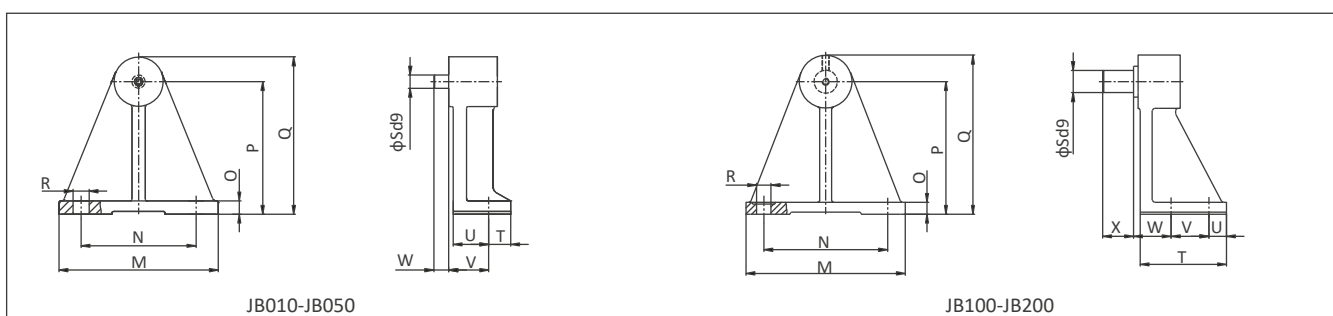

Type	M	N	O	P	Q	R	S	T	U	V	W	X
JB010	180	130	15	150	178	2- $\phi 17.5$	15	25	40	45	17	-
JB025	180	130	15	150	178	2- $\phi 17.5$	20	25	40	45	30	-
JB050	200	150	15	170	200	2- $\phi 17.5$	25	25	40	45	35	-
JB100	280	220	22	240	290	4- $\phi 22$	40	159	30	70	70	55
JB200	400	320	30	380	450	4- $\phi 33$	63	210	40	90	90	65

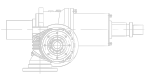

14.3 Torque-arm mounted (Please consult)

Applicable to opening and reversing devices.

JB

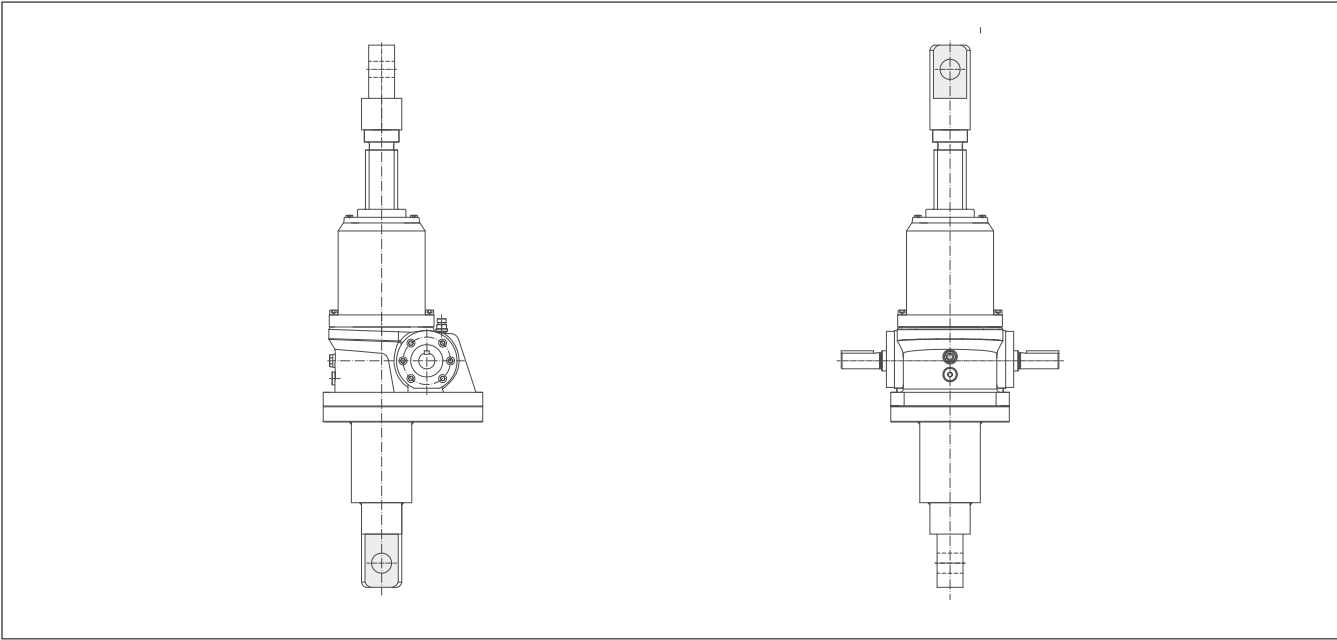

14.4 Oil

Oil amount reference table:

BU/BD/RU/RD		Oil Amount Reference Table						Unit:(L)
Assembly Position	Type	000#Extreme Pressure Grease				VG220(Worm Gear Oil)		
		JB010	JB025	JB050	JB100	JB200	JB300	JB500
D1、D3		0.13	0.16	0.2	0.27	0.75	3.1	7.3
D2		0.12	0.13	0.18	0.23	0.65	2.6	5.3

NU/ND		Oil Amount Reference Table						Unit:(L)
Assembly Position	Type	000#Extreme Pressure Grease				VG220(Worm Gear Oil)		
		JB010	JB025	JB050	JB100	JB200		
D1、D3		0.1	0.12	0.15	0.22	0.6		
D2		0.1	0.12	0.15	0.22	0.5		

 Note: Elevator operation process screw(nut) need to grease

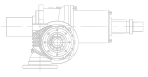

Note:

- The structure scheme, appearance diagram and other attached diagrams in sample are examples, there is no strict proportion requirement. (The unmarked dimension units are mm).
- The marked weight is average value, it has no constraint force

⚠ You must conform to the following instructions:

- To prevent accidents, all the rotation parts are added with protective covers according to the safety regulations of the nation and region.
- Before debugging, you should carefully read instruction book
- Gearbox is on running-permission status when delivered, you should add lubrication oil before putting it into running.
- The marked oil quantity in sample is only reference value, actual oil filling quantity should be the same with the mark on oil immersion lens.
- Lubrication oil viscosity should be selected according to working situation and application environment temperature of gearmotor.
- You can only apply lubrication oil of internationally famous brand

Product Function Mark



Oil glass



Breather



Oil filler



Oil drain





TGE Transmission s.r.o.

9. května 209,
268 01 Hořovice

Technical office Plzeň

Teslova 7b
301 00 Plzeň
info@tge.cz | www.tge.cz

Local dealer

